

Lighting and wiring

Trailers





CONTENT

Product presentation | 04



Full LED rear combination lamp for 24 V truck and trailer | 04
 LED hybrid rear combination lamp | 06
 LED hybrid round lamp | 08
 LED licence plate module and licence plate bracket | 10
 Underride guard | 11

Wiring systems | 12



EasyConn | 14
 SUPERSEAL | 16
 SUPERSEAL / EasyConn with flashing side marker lamps | 18

Lighting | 20



Multifunctional lamps | 20
 Round lamps | 24
 Shapeline | 26
 Clearance lamps | 28
 Licence plate lamps | 30
 Contour markings | 32
 Electronic ballast | 34
 Reverse lamps | 36
 Work lamps | 40
 Auxiliary light | 42
 Reflex reflector | 46

Wiring | 48



Main supply line | 48
 Front adapter | 49
 Front distributor | 50
 Rear adapter | 51
 Chains | 52
 Cables | 53
 Adapters | 55

Accessories | 59



Distributors | 59
 Battery box | 60
 Connector sets | 61
 Plug sets | 62
 Fuse sets | 63
 Underride guard | 64
 Accessories | 66
 LED lamp control units | 68

Things good to know | 70



Quality tests | 70
 IP protection classes | 71
 Icon overview | 72
 Plug connections and pin assignments | 74
 Info and tools on the web | 77
 Legal regulations | 78

FULL-LED REAR COMBINATION LAMP FOR 24 V TRUCK AND TRAILER



The full LED rear combination lamp for 24 V trucks and trailers impresses at first glance with its innovative design. The patented LED light curtain is particularly striking with a surface area of 144 cm² for the tail light and the reflex reflector behind it, and also for the dynamic direction indicator light. Optimal visibility of the vehicle is ensured thanks to the large light surface. This, in turn, guarantees a high level of safety.

The new rear combination lamp is also exceptionally robust. The lens is bonded to the housing and the two-colour polycarbonate (PC) external lens is impact-resistant. Overall, the rear combination lamp achieves protection class IP 6K9K, which means that it is not only dustproof but also resistant to cleaning with water under high pressure. With a size of 410 x 140 mm and an installation depth of just 55.5 mm, it is also extremely compact.

The electronics also meet the highest demands. The qualified and high-performance LEDs enjoy a long lifetime and have a low power consumption. In addition, the control for the flashing side marker lamps, the direction indicator failure control and also the load simulation for the stop and direction indicator lights are all integrated into the system. This ensures a high level of compatibility.

Another advantage of the rear combination lamp is its future viability. It has a mechanical interface for sensor technology, meaning that ultrasonic sensors can be connected on both sides, for example.

ⓘ And this is an important point: the connections on the rear combination lamp for auxiliary reverse lamps were developed in accordance with ECE R148. The function is therefore only active with the parking light switched on.

Take a look at all the advantages and functions of the rear combination lamp in the product video.



DISTRIBUTION OF THE LIGHT FUNCTIONS

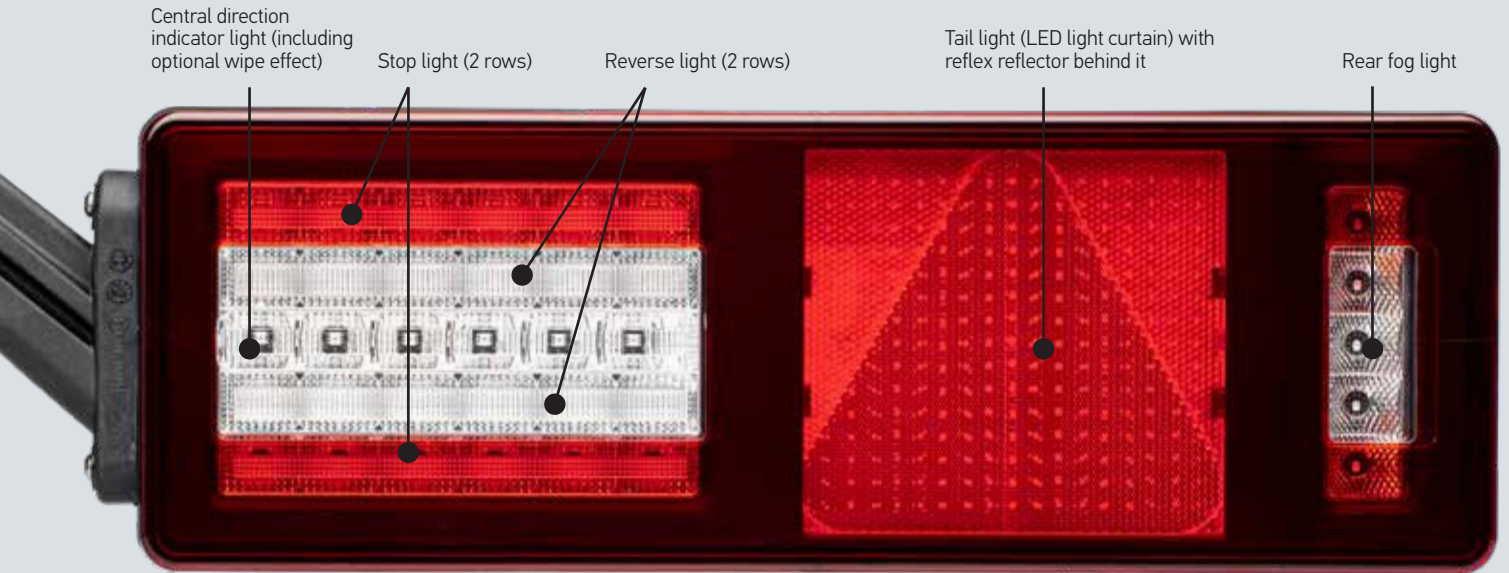

OVERVIEW OF CONNECTORS AND CONNECTIONS

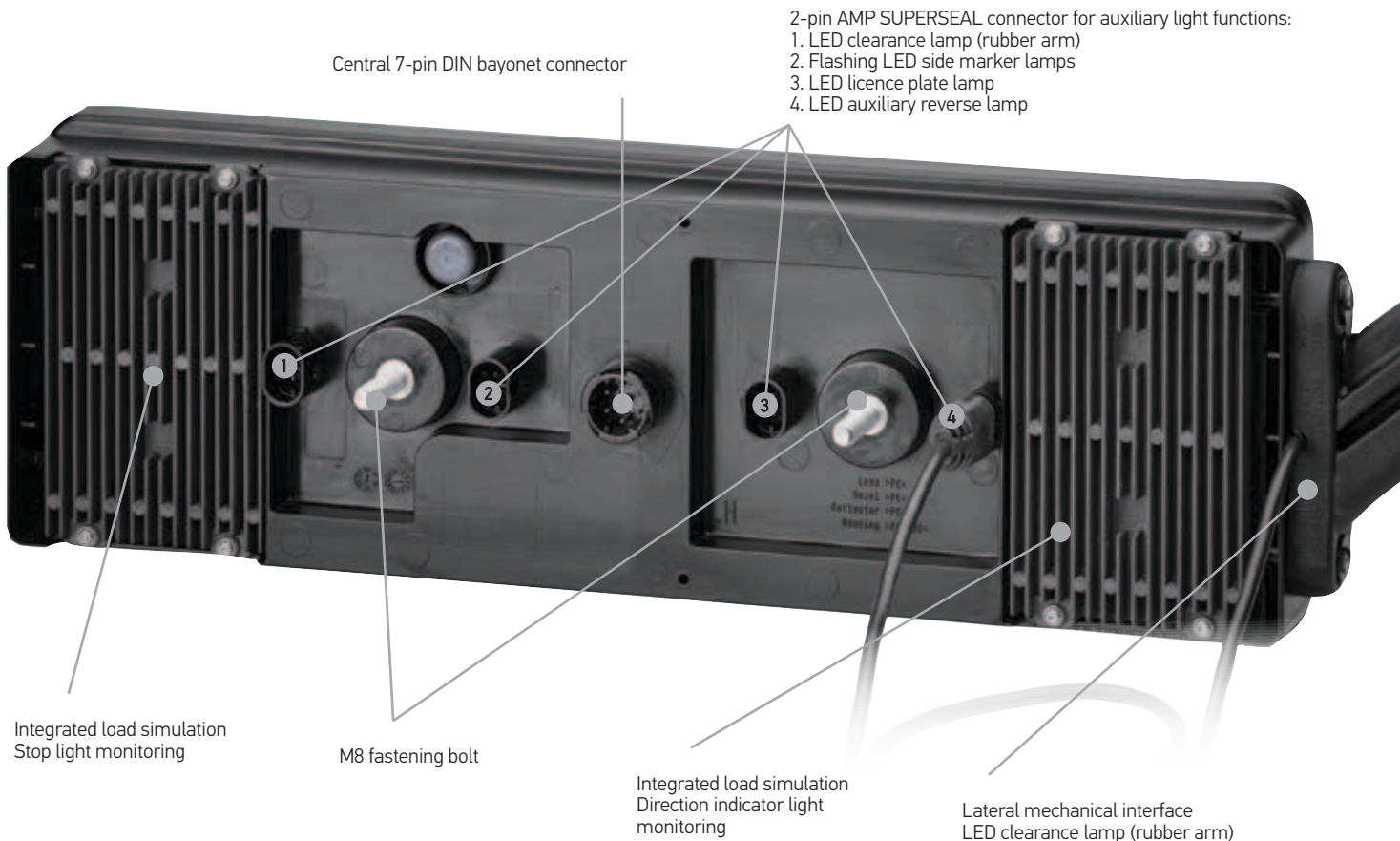

THE LED HYBRID REAR COMBINATION LAMP

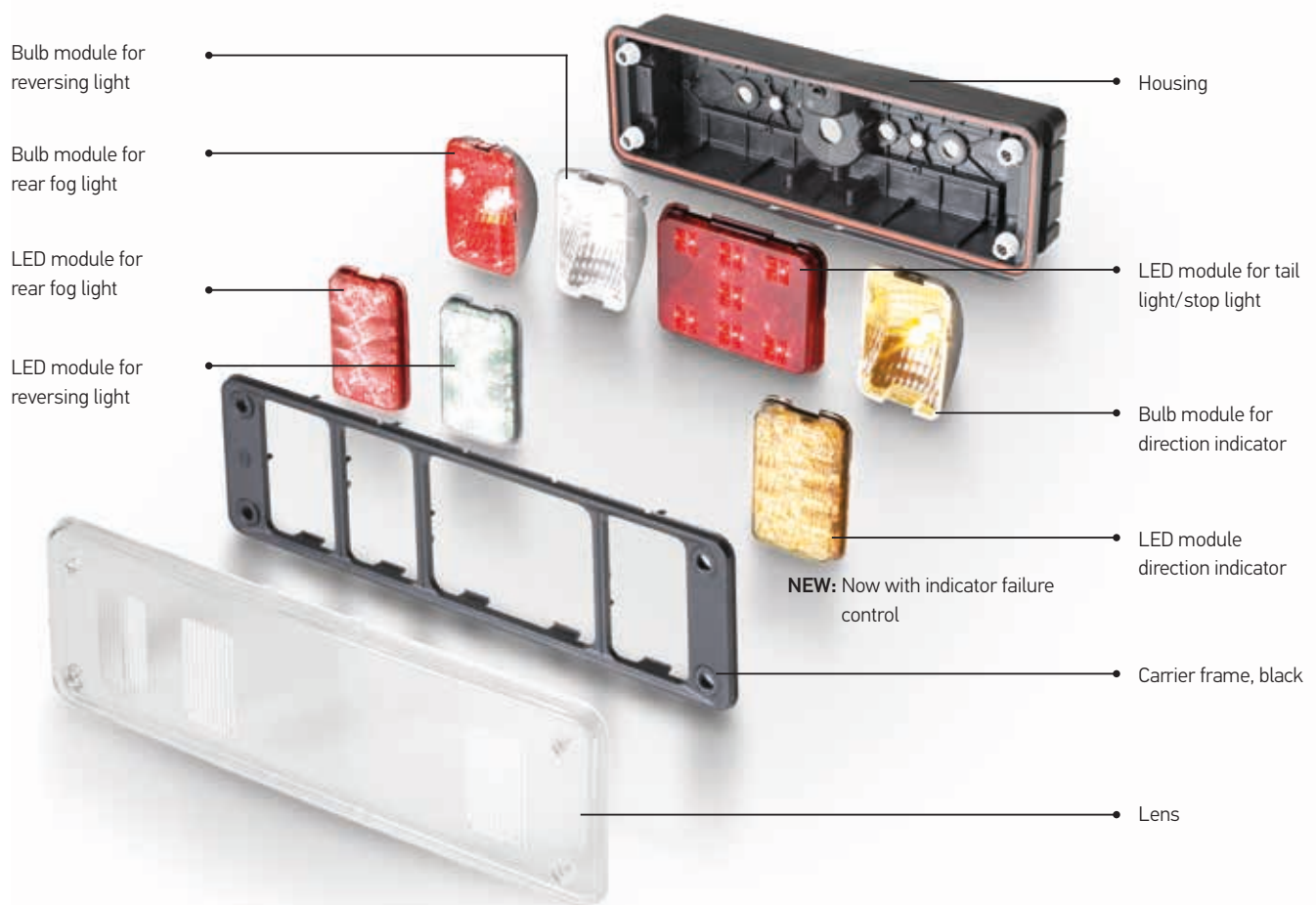

The modular 24 V trailer lamp by HELLA incorporates hybrid technology and is extremely versatile. Owing to the modular system and associated modularity of light sources and housing parts, the trailer lamp can be adapted flexibly to the requirements in each case. Several light functions, such as the tail, stop, direction indicator, rear fog and reversing light are combined in one single light.

While the design of the tail lamp and stop lamp is essentially based on an LED module, all other functions can be implemented in LED or classic filament bulb technology. The combination options available are almost limitless.

A changeover from filament bulb to highly energy-efficient LED technology is possible retrospectively at any time with no special tools required which offers plenty of scope for future conversions – the same applies for the replaceable lens which can be changed independently of the light source. A further highlight is the junction box function with additional outputs on the rear of the housing. This means that further auxiliary or light functions, such as a side marker light or clearance light, can be easily connected.

For many variants, the flash function from ECE 48, Series 6, Supplement 6 is now also additionally available. It requires a lateral flasher function, which is integrated in the module.



THE LED HYBRID ROUND LAMP



The new generation of this true classic! The round light series comprises a tail light/stop light/direction indicator light and a rear fog/reversing light combination. The lamps have a 140 mm dia. and are available either as a hybrid version (direction indicator as bulb) or as a full LED version. All versions are optionally available with integrated resistor to ensure the comfort function in the vehicle is available (for the stop light function). The light is downward compatible to the 001 685 series. The excellent level of product quality guarantees characteristics such as easy replacement of lenses in the event of damage or straightforward mounting, that can be done either on the left or right.

The series meets the ECE standard and is also approved for double mounting. The direction indicator failure pulse according to ISO 13207 is integrated in the LED versions. The light has integrated short-circuit protection. All the most common groups of cables are available.

Thanks to the new round light series, HELLA offers a highly-efficient, extremely economical, long-lasting light, due to thermal management.



FUNCTIONS



Hybrid
Stop light, direction indicator,
tail light



LED
Stop light, direction
indicator, tail light



LED
Fog light, reverse light



Accessory: chrome ring

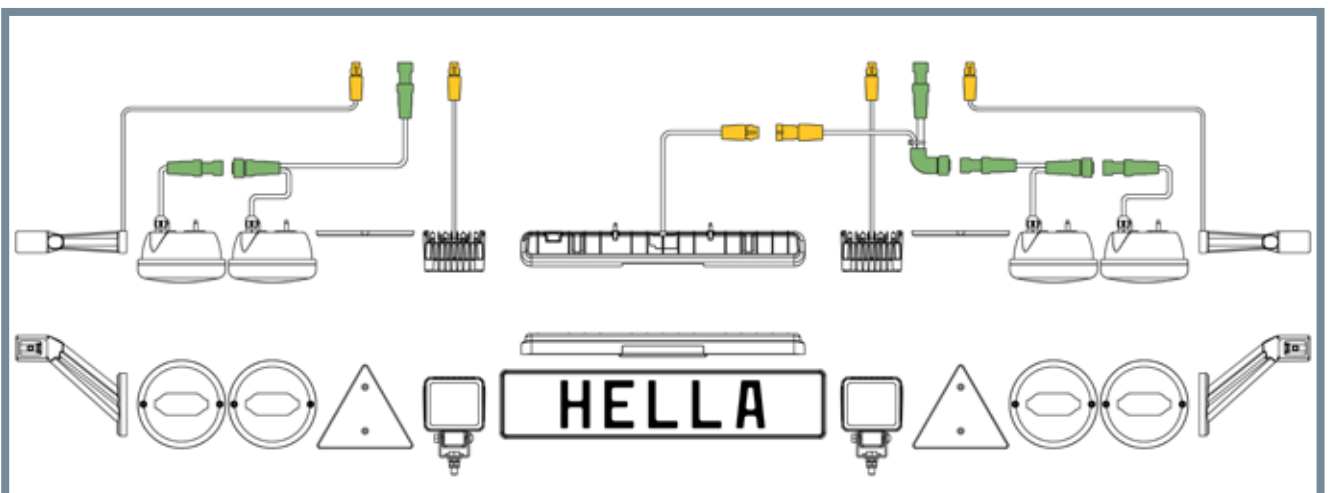

LED LICENCE PLATE MODULE AND LICENCE PLATE BRACKET

Central LED licence plate module with rear fog light



The central module, consisting of licence plate light and rear fog lamp, is designed to be centrally positioned at the rear of the vehicle. LED technology offers maximum reliability and vibration resistance. In this way the lamp will achieve a very long lifetime. The lamp complies with protection classes IP X9K and IP 6K7. This means that it is dustproof and protected against water penetration during high-pressure jet/steamjet cleaning and that it can withstand temporary immersion.

The licence plate module is available with either black or white housing. While the black variant has a rated voltage of 24 volts and is mainly used in the trailer sector, the lamp in the 12 volt model with white housing is specially designed for caravans and motorhomes. For the black 24 volt version, the requirement is that the lamp has to be ADR-certified in accordance with legal requirements.

Licence plate bracket with integrated LED licence plate lamp



Thanks to the integrated design of the LED licence plate lamp and the licence plate bracket, both elements are ideally matched to each other and do not have to be mounted separately. This saves time and costs. The product can be used for EU licence plates with heights of 110 mm and 120 mm. The integrated bracket clips with patented latching mechanism make mounting the licence plate quick and easy.

The waterproof electrical contact with AMP SUPERSEAL connectors makes the product particularly robust and durable. When cleaning the vehicle with a high-pressure jet cleaner, the licence plate bracket and the integrated LED licence plate lamp withstand the water without any problems. The product is also ADR/GGVs certified and therefore also suitable for vehicles used for transporting hazardous goods.

UNDERRIDE GUARD

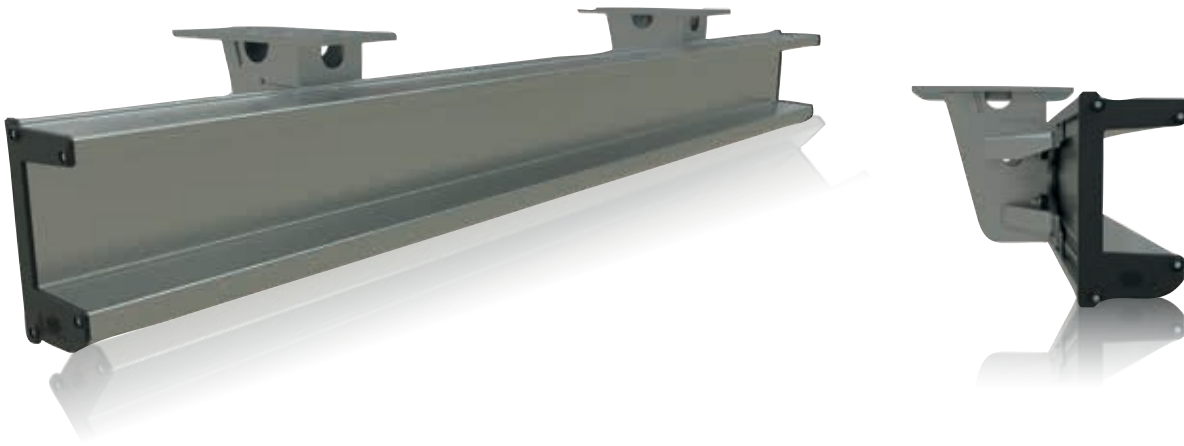

Trucks are becoming even safer: Tougher requirements for the underride guard

The following can be fatal: when smaller vehicles such as cars or bicycles slide under a truck, extremely serious injuries are often the result. The underride guard stops vehicles before they literally end up under the wheels, thus preventing the most serious consequences of accidents in many cases.

Pile-up collisions are a particularly high risk. So as to ensure that the rear underride guard also withstands the impact of heavy cars, the requirements for the component have been modified. In comparison to the past, the test forces stipulated in the new UNECE R58-03 have been almost doubled!

The new underride guard from HELLA easily meets these new requirements. The component is made of resistant aluminium and is available with two different kinds of brackets so that it can be fitted to vehicles with different chassis heights.

On request, the underride guard can also be provided with customisable hole pattern milling, painted in various RAL colours and also fitted with a rubber spray flap. The product thus offers the right solution for every customer.

Mounting examples



WIRING SYSTEMS – THE HIDDEN TECHNOLOGY

The connector systems

The EasyConn connector system is made up of 2, 7, and 15-pin connector housing and female connector housing. For even easier mounting on trailers, their diameter has been significantly reduced. SUPERSEAL and 7-pin DIN bayonet connectors can be used to extend the system. This provides customers with even greater flexibility when designing, retrofitting, or converting the lighting system for their trailers.

The 15-pin front, central and rear main cables in the wiring are still treated as a constituent part of the tried-and-tested EasyConn system. The wiring system makes it quick and easy to connect new products to various existing systems. This not only saves time and increases flexibility, but also minimises storage costs for the aftermarket, for workshops, and for fleet operators.

15-pin EasyConn connector

The 15-pin EasyConn connector housing and female connector housing connect the front adapter, the main supply cable and the rear adapter to one another.



15-pin EasyConn connector with connector set II

The tried-and-tested 15-pin plug connections are also available as a connector set, making it easy to implement customer-specific requests and repairs.



The 15-pin explosion drawing of the EasyConn II connector



The plug connections are tested in compliance with protection class **IP 6K9K** and guarantee absolute leak tightness. **6K** = dustproof, **9K** = resistant to high pressure jet/steamjet cleaning

Systematic colours

Straightforward connection of all components with process reliability, thanks to the colour system from HELLA.



7-pin DIN bayonet* connector

Our round lamp system, and also third-party products, can be connected via a 7-pin DIN bayonet connection.



7-pin EasyConn connector

Rear combination lamps are connected by the 7-pin connector housing and female connector housing to the EasyConn system.



2-pin EasyConn* connector

The 2-pin EasyConn connector housing and female connector housing allow, for example, SMLR (side marker lamps), position lamps, clearance lamps and 2-pin additional functions to be connected.



2, 3 and 4-pin SUPERSEAL connectors

With the 2, 3 and 4-pin SUPERSEAL connection, customers have access to yet another reliable product for connecting single-function lamps.



Quick link

Our Quick Link press connection: flexible and safe mounting of single-function lamps to our HELLA flat cable.

* Version also available in angled design

- The coupling is simply connected to the flat conductor, the cable.
- And then fixed with the clamping piece.
- Press together with the mounting pliers.
- Finished.



Quick link wiring: flexible and secure mounting

The quick link wiring system is a further contact option that stands out thanks to fast and straightforward installation. Lamps fitted with HELLA quick link wiring consist of a cable with a coupling. The cables are delivered in different lengths depending on requirements. These lamps can contact a 2-wire flat cable in any place. They may also be used for dangerous goods transport (GGVS / ADR).

WIRING AND LIGHTING SYSTEM WITH EASYCONN



EasyConn wiring system for multi-function light example

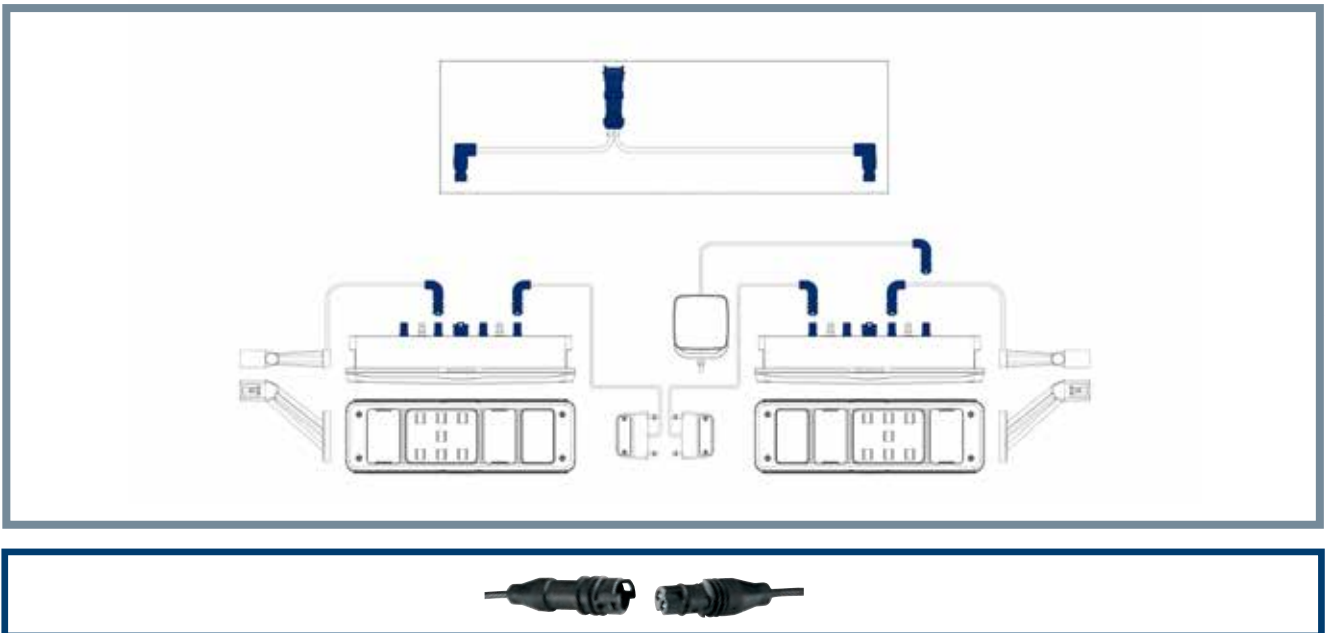

The modular hybrid rear lamp takes over the distributor function for all the lighting functions required according to the German road traffic licensing regulations (StVZO). These are strictly separated from other special lighting and auxiliary functions by a dedicated distributor circuit. This provides the advantage of a cost-effective, easy to install lighting system with a modular structure. Subsequent, hassle-free expansion of the standard system is also possible with additional EasyConn components and other lighting and special functions.

Only the rear adapter is replaced to use our new round light system. All other cable components such as the main power supply and the front adapter remain the same. Connection is via DIN bayonet. All single-function lights remain unchanged with an EasyConn connection and can, in this way, be integrated into the round light system.

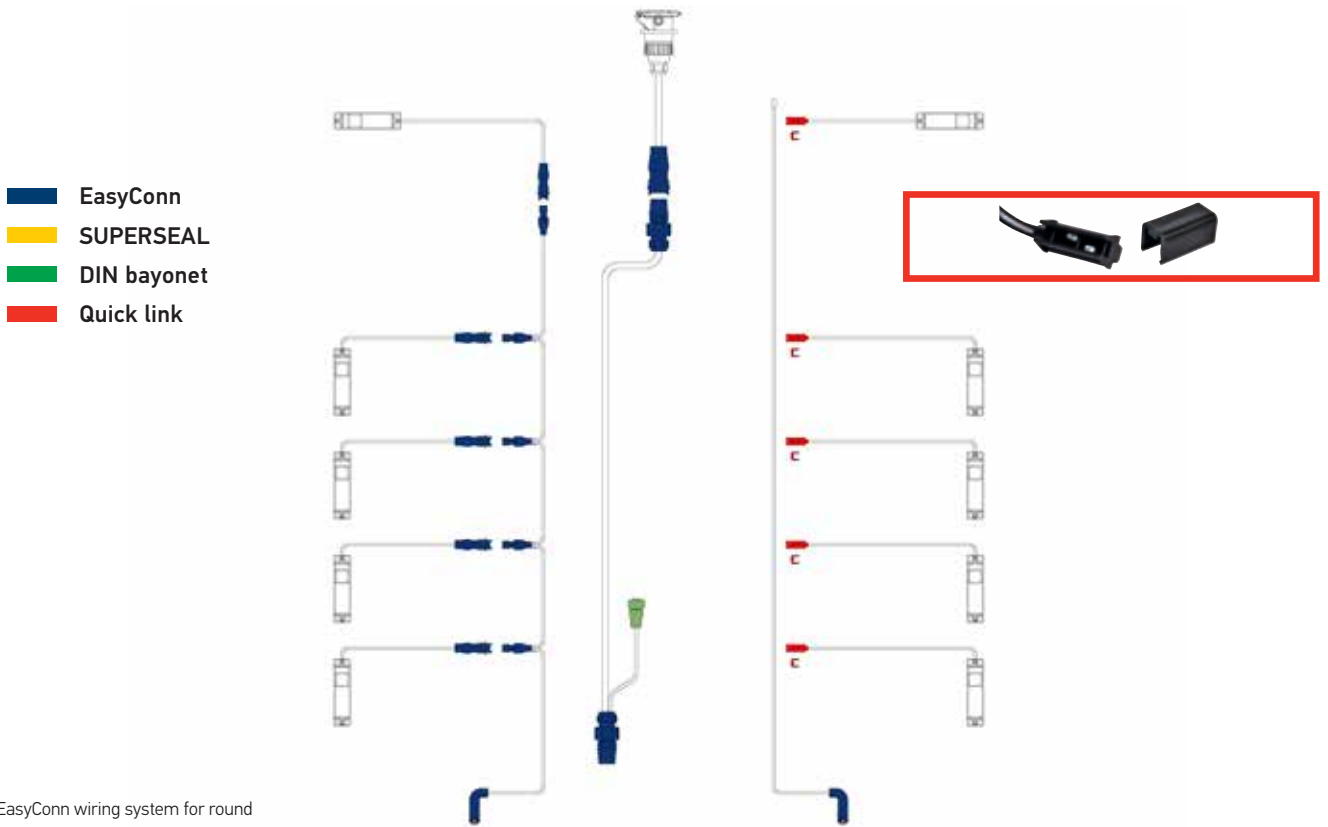

EasyConn wiring system for round light example

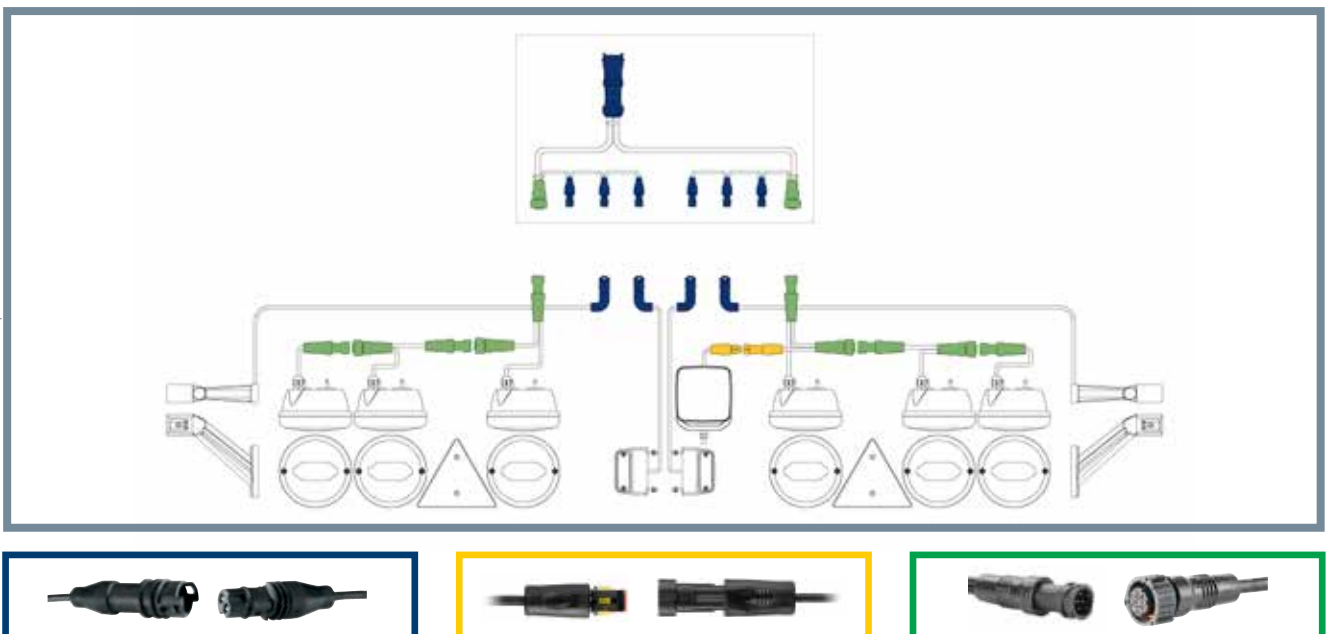

WIRING AND LIGHTING SYSTEM WITH SUPERSEAL

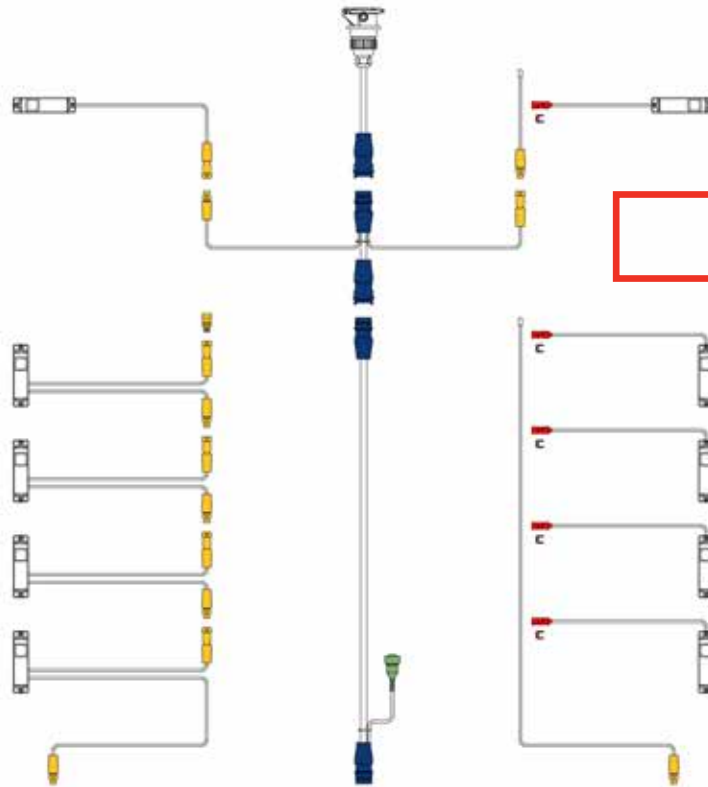

SUPERSEAL wiring system for multi-function light example

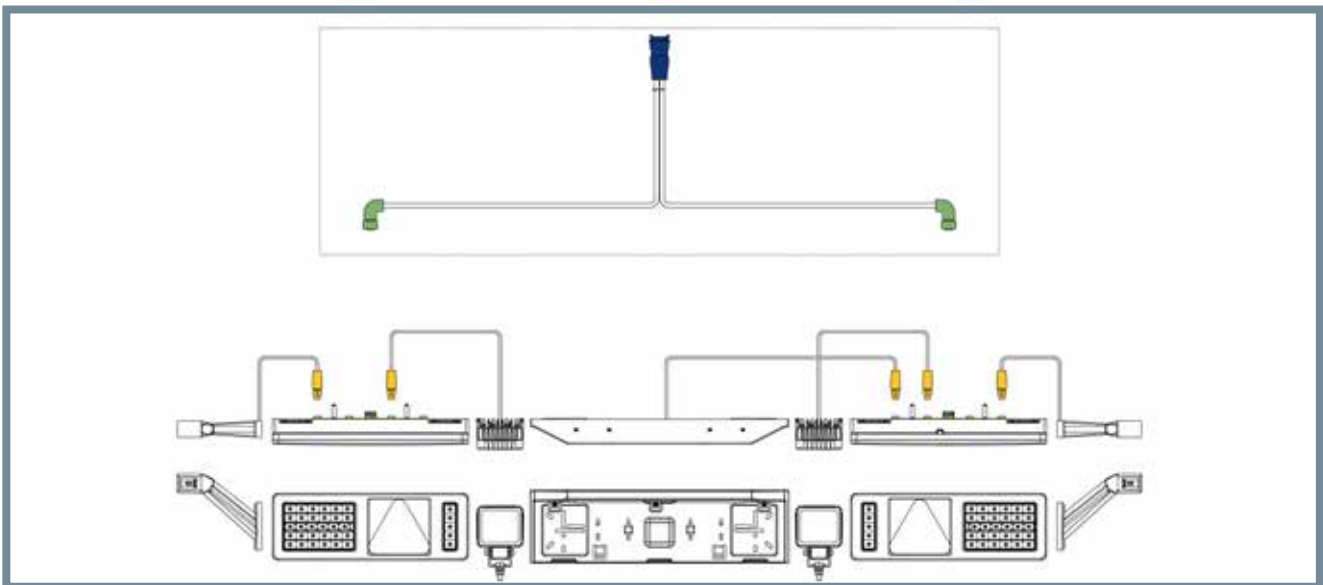

The modular hybrid rear combination lamp also serves as a distributor for our DIN bayonet and SUPERSEAL versions. This is where all the lighting functions required according to the German road traffic licensing regulations (StVZO) are connected. Special and auxiliary functions continue to be strictly separated from the standard by means of a dedicated distributor circuit. This provides the advantage of a cost-effective, easy to install lighting system with a modular structure as well as hassle-free subsequent expansion of the standard system with additional EasyConn, DIN bayonet and SUPERSEAL components.

Only the rear adapter must be replaced to use our new round light system. All other cable components such as the main power supply and the front adapter remain the same. Connection is via DIN bayonet. All single-function lights are now connected with a SUPERSEAL connector.

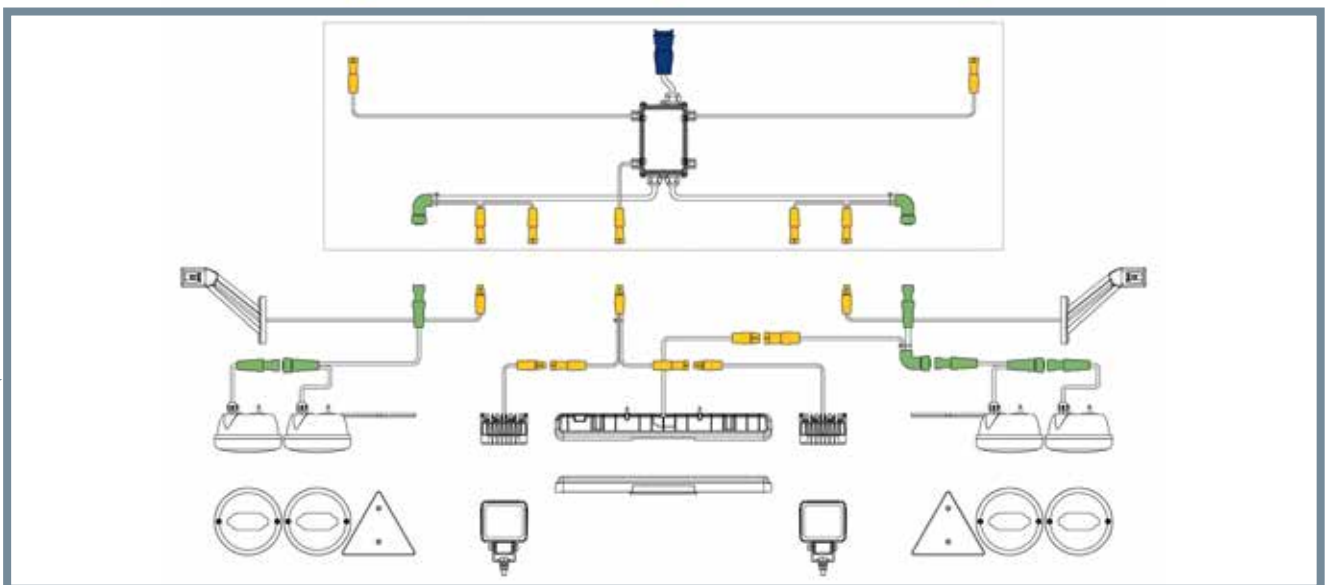
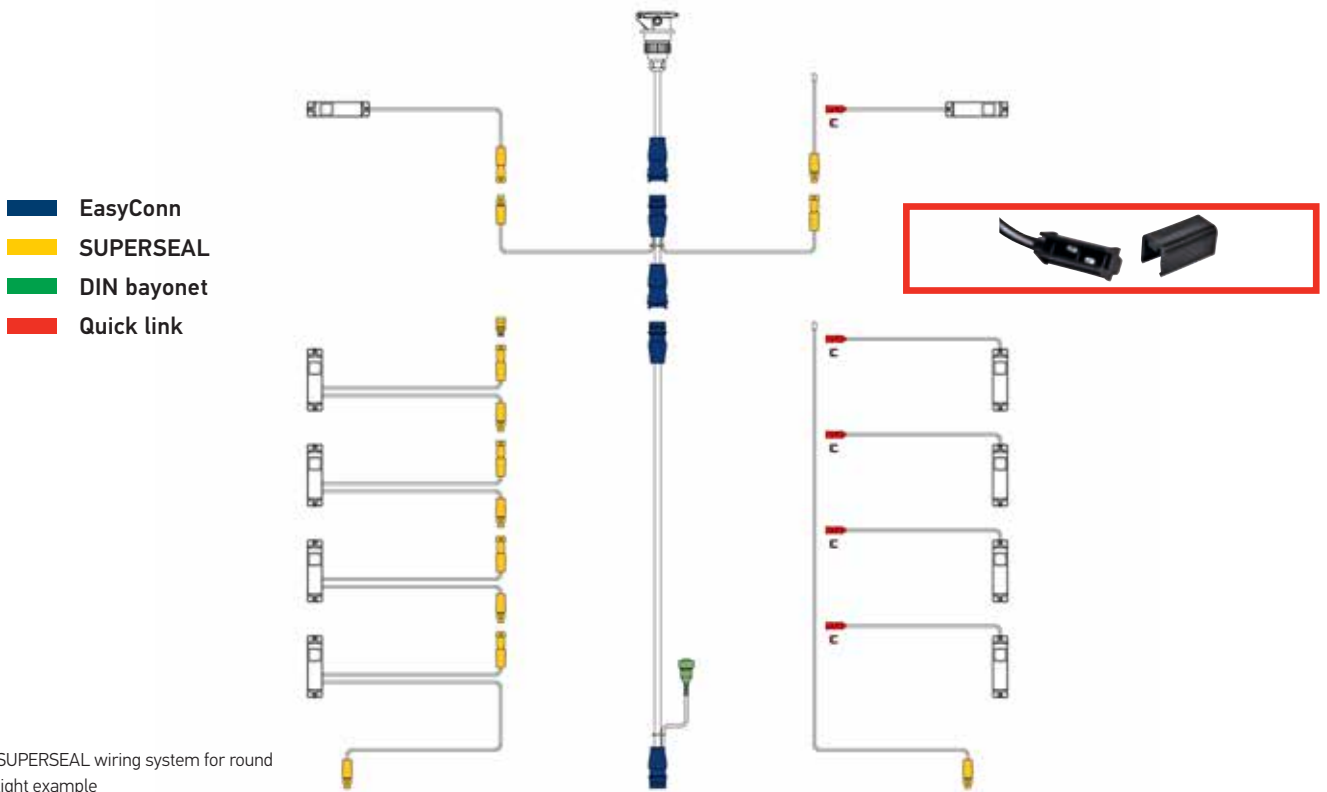

WIRING AND LIGHTING SYSTEM WITH SUPERSEAL OR EASYCONN WITH FLASHING SIDE MARKER LIGHTS

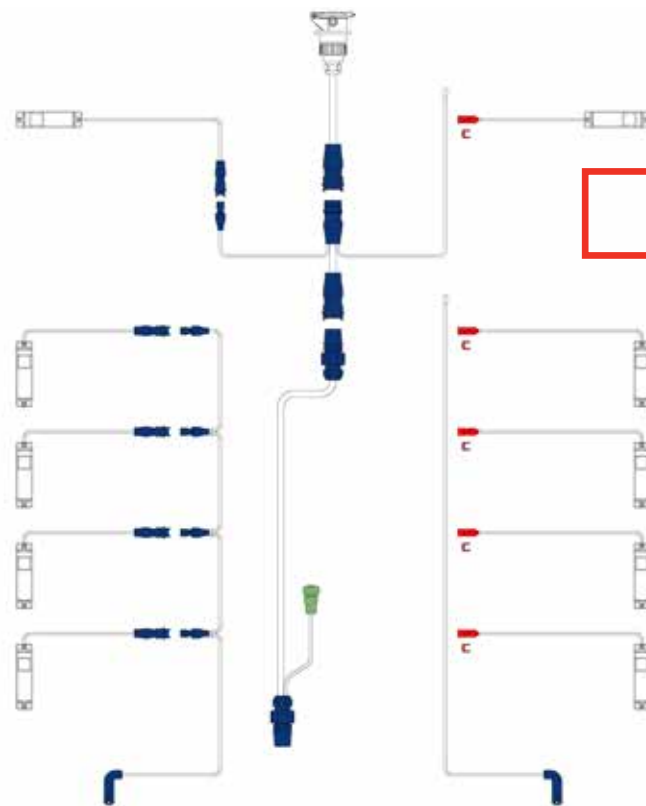

EasyConn wiring system

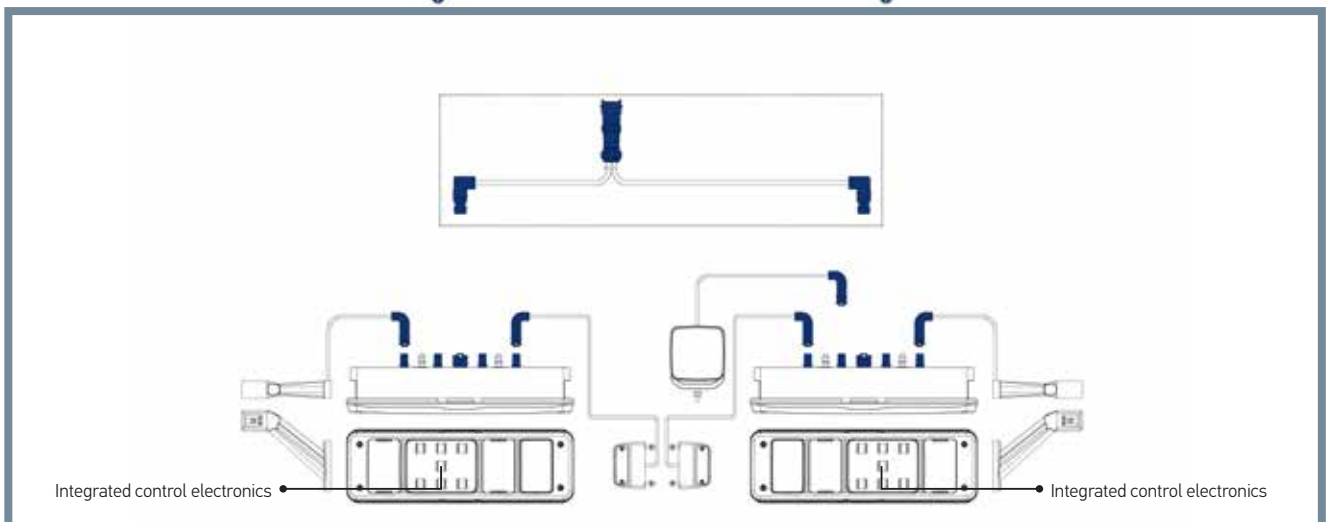

Control electronics for flashing side marker lights

The control electronics serves to meet the ECE R48 Revision 6. It serves a electronic ballast to make conventional side marker lights flash. Furthermore it conforms to legislation with existing direction indicator failure controls through evaluation of the rear direction indicator. The control unit monitors functioning of the rear direction indicator. In the event of any fault, it switches off the flasher function of the side marker lamps to ensure that the failure control of the towing vehicle conforms to the law. The compact control electronics design permits installation in a

distribution box. Only one control unit is required and thanks to the full encapsulation, the control electronics is very robust and watertight. The high degree of EMC protection allows use in very challenging environments. The control electronics is suitable for use with all LED side marker lights.

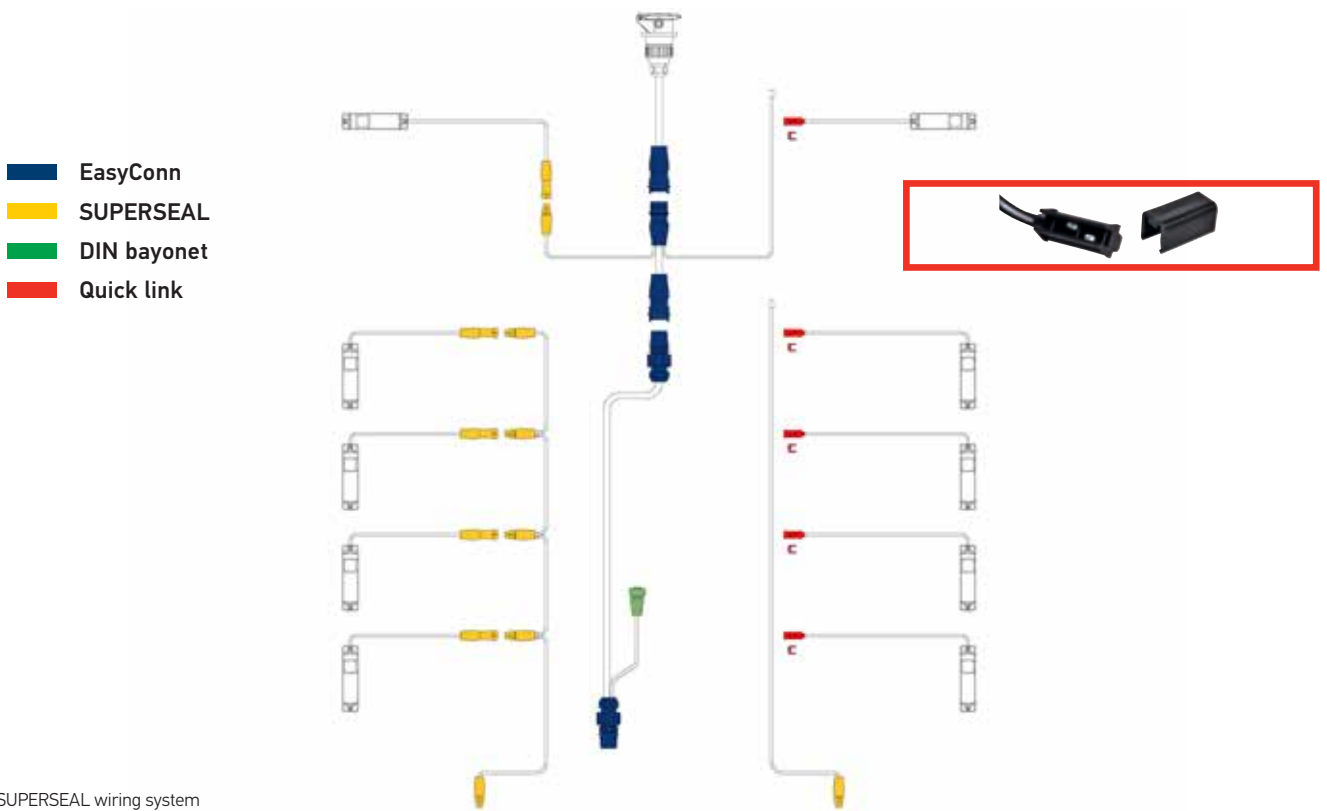

SUPERSEAL wiring system

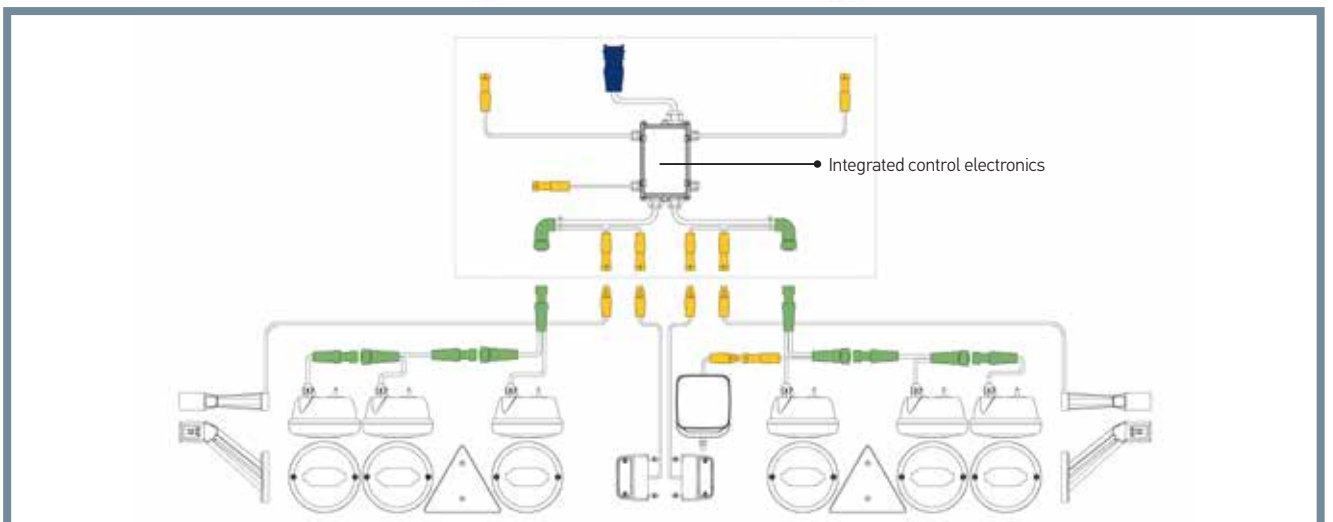

MULTI-FUNCTION LIGHTS



Full LED rear combination lamp for 24 V trucks and trailers

Full-LED rear combination lamp with tail light, stop light, direction indicator light, rear fog light, reverse light, 12 red LEDs for tail light function, with pulse for direction indicator failure control.

Operating temperature	-40 °C to +60 °C
Protection class	IP 6K9K
Type approval	ECE E24 148R-00 5934, 150R-00 5934
Connection	Central 7-pin DIN bayonet connector, 2-pin AMP SUPERSEAL connector for auxiliary lighting functions

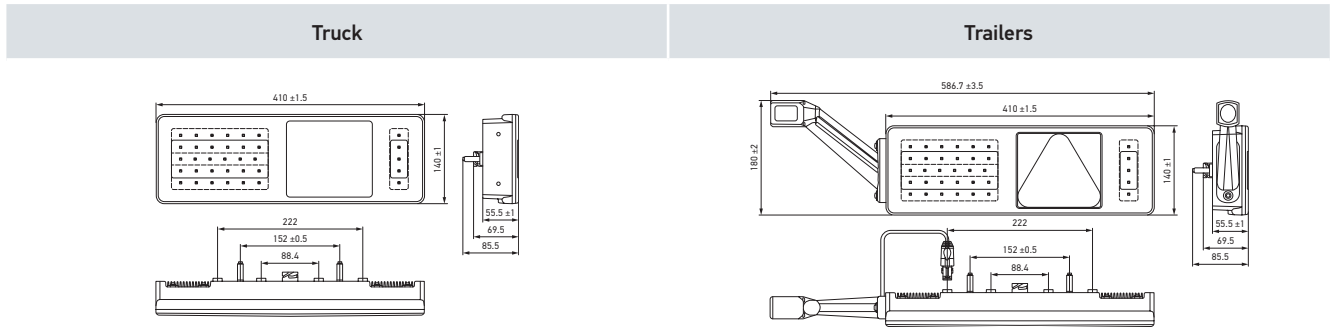

Product picture	Version	Function					Surface mounting		Part number		
		Direction indicator light, flashing	Direction indicator light, wiping	Rubber arm	Load simulation, direction indicator light	Load simulation, stop light	Electronics for flashing side marker lamps	Right		Left	
	Truck	■						■	■	2VP 340 970-701	
			■					■	■	2VP 340 970-711	
	Trailers	■		■					■	2VP 340 970-037	
		■		■			■	■		2VP 340 970-047	
			■	■					■		2VP 340 970-337
			■	■				■	■		2VP 340 970-347
		■		■	■		■	■		■	2VP 340 970-437
		■		■	■		■	■	■		2VP 340 970-447
			■	■	■		■	■		■	2VP 340 970-537
	■	■	■		■	■	■		2VP 340 970-547		



MULTI-FUNCTION LIGHTS

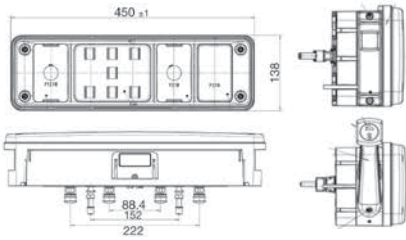

LED hybrid rear combination lamp / full LED rear combination lamp

Modular multifunctional rear combination lamp for horizontal surface mounting, optionally as a hybrid or full LED variant with the following functions: tail light, stop light, direction indicator light, triangular reflex reflectors, fog light and reverse light, with the stop and tail light function in LED as standard.

Operating temperature -40 °C to +50 °C
Protection class Lamp: IP 5K4K, LED module: IP 6K9K

Connector type on the light				LED function					Auxiliary	Surface mounting				Part number
7-pin EasyConn pin housing	2-pin EasyConn socket housing	7-pin DIN pin housing	2-pin SUPERSEAL pin housing	Reverse light	Rear fog light	Direction indicator light	Stop light	Tail light	Rubber arm	Right	Left	*Integrated direction indicator failure control	Flash SMLR**	
■	■						■	■	■		■			2VP 340 961-117
■	■						■	■	■	■				2VP 340 961-127
		■	■				■	■	■		■			2VP 340 961-437
		■	■				■	■	■	■				2VP 340 961-447
■	■			■	■	■	■	■	■		■	■		2VP 340 966-117
■	■			■	■	■	■	■	■	■		■		2VP 340 966-127
		■	■	■	■	■	■	■	■		■	■		2VP 340 966-417
		■	■	■	■	■	■	■	■	■		■		2VP 340 966-427
■	■						■	■	■		■		■	2VP 340 965-117
■	■						■	■	■	■			■	2VP 340 965-127
		■	■				■	■	■		■		■	2VP 340 965-437
		■	■				■	■	■	■			■	2VP 340 965-447
■	■			■	■	■	■	■	■		■	■	■	2VP 340 967-117
■	■			■	■	■	■	■	■	■		■	■	2VP 340 967-127
		■	■	■	■	■	■	■	■		■	■	■	2VP 340 967-417
		■	■	■	■	■	■	■	■	■		■	■	2VP 340 967-427

Further variants with and without lane departure lamp on request.
 * BAK abbreviated in German = direction indicator failure control
 ** Flash = side direction indicators

MULTI-FUNCTION LIGHTS

ACCESSORIES REQUIRED FOR LED HYBRID / FULL LED REAR COMBINATION LAMP (PAGE 22)

Cover	8XS 340 092-017 must urgently be used
EasyConn lock	9HV 340 812-007 open connections must be closed
SUPERSEAL lock	9XX 340 814-017 open connections must be closed



"COLUNA" full LED rear combination lamp

Full LED 5-chamber light with tail light, stop light, direction indicator, rear fog light, and reversing light. With triangular reflex reflector for horizontal mounting on 24 V trailers. 12 white LEDs for tail light function arranged as a light curtain. With fastening bolt from the rear. With pulse for direction indicator failure monitor.

Additional variants also available on request in 12 volts and without flashing impulse.

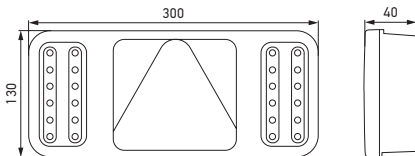

Operating temperature	-40 °C to +50 °C
Protection class	IP 6K9K

Product picture	Connector type on the light			Cable	Function					Surface mounting		Part number	
	7-pin EasyConn pin housing	7-pin DIN pin housing	6.3 mm flat receptacles		Reverse light	Rear fog light	Direction indicator light	Stop light	Tail light	Right	Left		
	■			1,000	■	■	■	■	■		■	2VP 345 900-017	
	■				■	■	■	■	■	■			2VP 345 900-027
		■			■	■	■	■	■	■		■	2VP 345 900-097
		■			■	■	■	■	■	■	■		2VP 345 900-107
			■	3,000	■	■	■	■	■			■	2VP 345 900-137
			■		■	■	■	■	■	■	■		2VP 345 900-147

ROUND LIGHTS



Hybrid and full LED rear combination lamp

The series comprises a hybrid tail, stop, direction indicator light combination (direction indicator function executed with bulb), a full LED tail, stop, and direction indicator combination and also a full LED rear fog light and reverse light combination. Tail light function each with 6 LEDs. Lens replaceable if damaged. Suitable for left-hand and right-hand mounting.

Operating temperature	-40 °C to +50 °C
Protection class	Lamp: IP 5K4 LED module: IP 6K9K

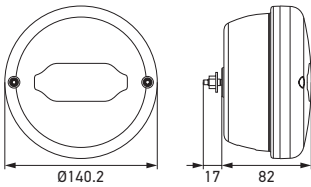

Hybrid tail light, stop light, direction indicator light combination

Full LED tail light, stop light, direction indicator light combination

Full LED rear fog light, reverse light combination



Application example



ROUND LIGHTS

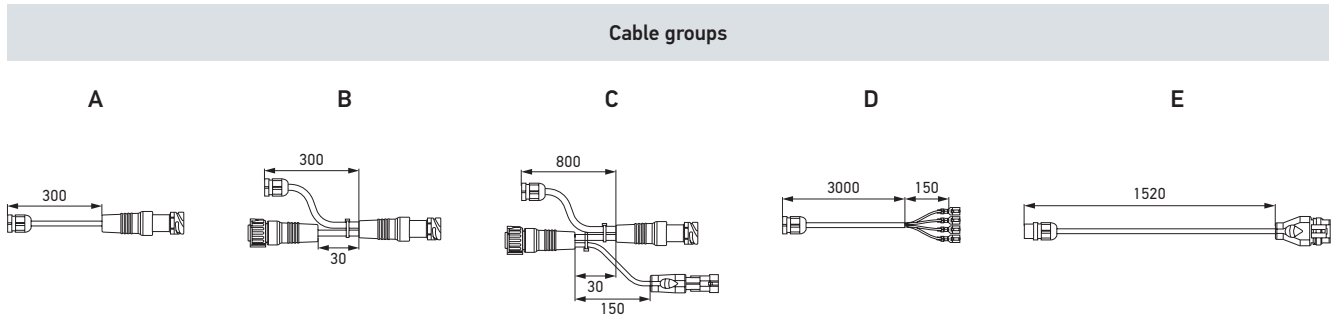

Cable group	Connector type on the light					Cable	Function							Part number
	7-pin DIN pin housing	7-pin DIN socket housing	2-pin SUPERSEAL pin housing	6.3 mm flat receptacles	4-pin SUPERSEAL socket		Length in mm	Resistance brake	Reverse light LED	Rear fog light LED	Indicator lamp LED	Direction indicator bulb	Stop light LED	
A	■					300	■				■	■	■	2SD 013 155-007
B	■	■				300					■	■	■	2SD 013 155-017
D				■		3,000	■				■	■	■	2SD 013 155-027
D				■		3,000					■	■	■	2SD 013 155-037
B	■	■				300	■				■	■	■	2SD 013 155-047
E					■	1,500	■				■	■	■	2SD 013 155-057
B	■	■				300				■		■	■	2SD 013 155-107
D				■		3,000	■			■		■	■	2SD 013 155-117
A	■					300				■		■	■	2SD 013 155-127
E					■	1,500				■		■	■	2SD 013 155-137
C	■	■	■			800	■	■	■					2SD 013 155-207
B	■	■				800	■	■	■					2SD 013 155-217
D				■		3,000	■	■	■					2SD 013 155-227

ShapeLine for Trailer Rear Bumper Concepts

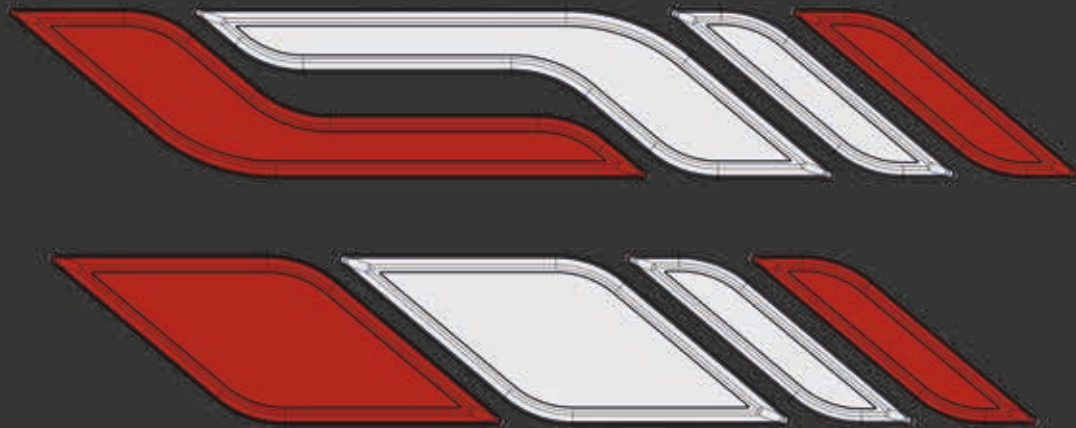

SHAPELINE

The variety of shapes and the various combination options, paired with a technically optimised product design, make the new ShapeLine lamp series a true innovation in vehicle lighting! Whether at the front, side or rear of a vehicle, every vehicle series – whether big or small – can have a unique and, above all, consistent look using a customised configuration and arrangement of lamps. This allows us meeting the demands of vehicle manufacturers with lower numbers of manufactured vehicles. Along with innovative technology and the familiar high quality of HELLA's products, the variety of shapes of ShapeLine lights provide you with infinite design freedom. Design your light – with HELLA ShapeLine!

Visit the configuration tool at www.hella.com/shapeline

Further information on request. Connecting cables can be found in the "Adapter" chapter starting on page 48.



HELLA
Scheinwerfer

HELLA
Flat Beam
1800 LED

PB FV 700

CLEARANCE LAMPS



LED rubber arm clearance light

With 3 LEDs, vertical or horizontal mounting, side marker light, position light, clearance lamp, power consumption 9 – 32 V / 1.8 W.

Operating temperature	-40 °C to +50 °C
Protection class	IP 6K9K
Connection	Various options (see program overview)



Vertical installation	Vertical mounting (short)	Horizontal installation
-----------------------	---------------------------	-------------------------

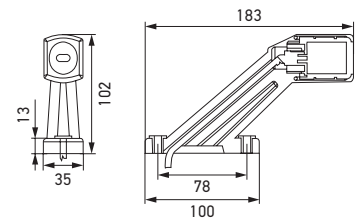
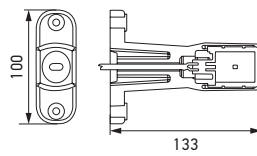
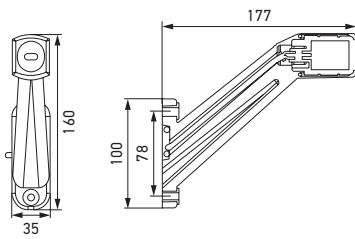

Application example



Product picture	Connector type on the light					Cable	Surface mounting		Part number
	2-pin EasyConn 90°	2-pin SUPERSEAL socket housing	2-pin EasyConn socket housing	2-pin Quick Link	6.3 mm flat receptacles		Length in mm	Right	
	■					500		■	2XS 011 744-017
	■						■		2XS 011 744-027
					■	3,000		■	2XS 011 744-037
					■		■		2XS 011 744-047
		■				2,000		■	2XS 011 744-057
		■					■		2XS 011 744-067
				■		500		■	2XS 011 744-077
				■			■		2XS 011 744-087
			■				■		2XS 011 744-107
			■					■	2XS 011 744-117
				■		1,500	■		2XS 011 744-127
				■				■	2XS 011 744-137
				■		1,000	■		2XS 011 744-187
				■				■	2XS 011 744-197
		■			800	■		2XS 011 744-207	
		■					■	2XS 011 744-217	
				■		500	■	■	2XS 011 768-007
	■						■	■	2XS 011 768-017
			■				■	■	2XS 011 768-027
		■				2,000	■	■	2XS 011 768-037
					■		■	■	2XS 011 768-077
			■			500		■	2XS 011 769-017
			■				■		2XS 011 769-027
	■							■	2XS 011 769-037
	■						■		2XS 011 769-047
		■				2,000		■	2XS 011 769-057
		■					■		2XS 011 769-067

LICENCE PLATE LIGHTS



Central LED licence plate module with rear fog light

Licence plate light and rear fog light, for central positioning at the rear of the vehicle, screw fixing, connection: 3-pin AMP SUPERSEAL

Operating temperature -40 °C to +60 °C
Protection class IP X9K, IP 6K7

Product picture	Voltage	Housing colour	ADR certification	Cable	Part number
				Length in mm	
	12 V	white		175	2NE 340 980-017
	24 V	Black	■	1,600	2NE 340 980-007



Licence plate bracket with integrated LED licence plate lamp

Licence plate light white, with 4 LEDs, made of PMMA / PC / PP, screw fixing (screws not included), suitable for EU licence plates measuring 110 mm and 120 mm in height, connection: 2-pin AMP SUPERSEAL

Operating temperature -40 °C to +60 °C
Protection class IP 5KX, IP X9K

Product picture	Voltage	Housing colour	Cable	Part number
			Length in mm	
	24 V	Black	1,500	2KA 329 280-017

LICENCE PLATE LIGHTS

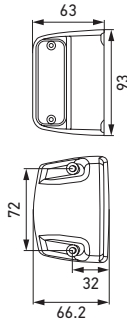

LED licence plate light

For mounting on the right or left next to the licence plate (520 x 120 mm), only 1 lamp needed for illumination. Clear lens, with 4 LEDs, black plastic housing, 2 fastening screws M5 x 35.

Operating temperature -40 °C to +50 °C
Protection class IP 6K9K

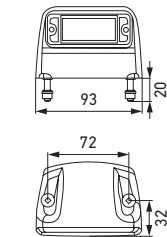

LED licence plate light

For mounting on the right and left next to the licence plate (520 x 120 mm), two lamps required for illumination. Clear lens with pattern, with 2 LEDs, grey plastic housing. 2 fastening screws M5 x 35.

Operating temperature -40 °C to +50 °C
Protection class IP 5K9K

Product picture	Connector type on the light					Cable Length in mm	Surface mounting		Part number
	2-pin EasyConn 90°	2-pin SUPERSEAL socket housing	2-pin EasyConn socket housing	2-pin Quick Link	6.3 mm flat receptacles		Single	Double	
					■	2,000	■		2KA 010 278-037
				■		500	■		2KA 010 278-047
			■			500	■		2KA 010 278-057
		■				1,350	■		2KA 010 278-097
	■					1,300	■		2KA 010 278-077
					■	2,000		■	2KA 012 271-037
				■		500		■	2KA 012 271-047
			■			500		■	2KA 012 271-057
		■				1,300		■	2KA 012 271-067
	■					1,300		■	2KA 012 271-077

CONTOUR MARKINGS

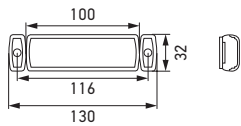

LED position lamp / side marker lamp / tail lamp with reflex reflector

LED position lights with reflex reflector

Suitable for horizontal and vertical mounting. With 1 white LED, white light, and black housing. With horizontal mounting, the LED field must point to the outer edge of the vehicle. The light is fixed using the lateral mounting holes or using a bracket.

LED side marker lamp with reflex reflector

Suitable for horizontal surface mounting. With 1 yellow LED, yellow light, and black housing. The light is fixed using the lateral mounting holes or using a bracket.

LED tail lamp with reflex reflector

Suitable for horizontal and vertical mounting. With 1 red LED, red light, and black housing. With horizontal mounting, the LED field must point to the outer edge of the vehicle. The light is fixed using the lateral mounting holes or using a bracket.

Operating temperature -40 °C to +60 °C
Protection class IP 6K9K

Accessories: bracket

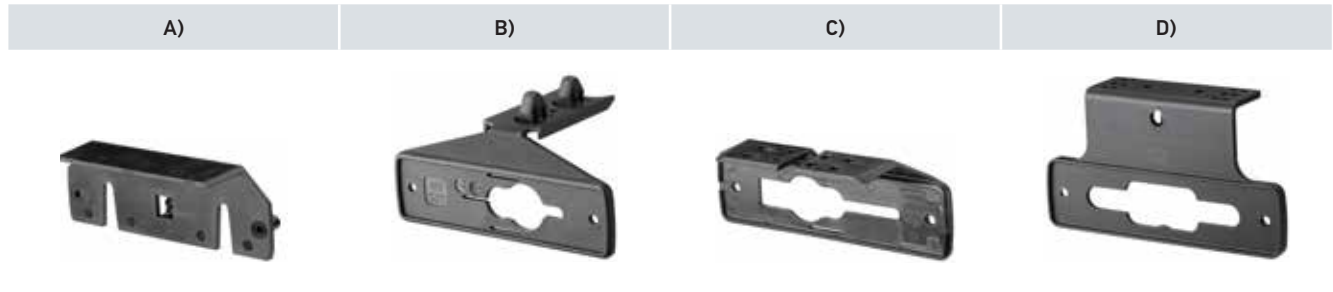

A) 8HG 160 409-00

B) 8HG 340 413-00

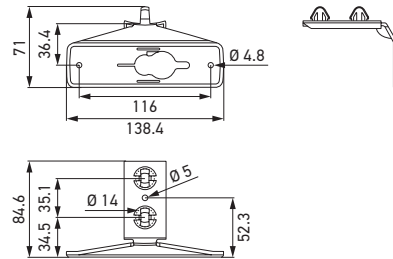
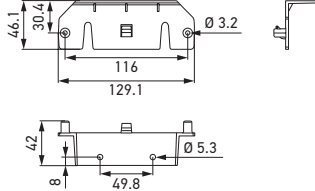

C) 8HG 340 489-00

D) 8HG 340 587-00

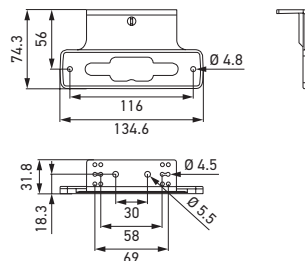
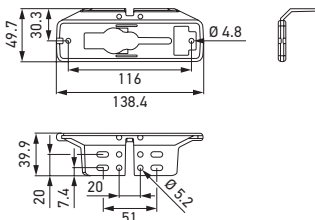

Product picture	Connector type on the light						Cable	Surface mounting		Part number
	2-pin SUPERSEAL pin housing	2-pin SUPERSEAL socket housing	2-pin EasyConn connector housing	2-pin Quick Link	6.3 mm flat receptacles	Open cable ends		Length in mm	Horizontal	
					■		2,130	■	■	2PG 008 645-107
					■		4,930	■	■	2PG 008 645-127
			■				1,300	■	■	2PG 008 645-337
				■			300	■	■	2PG 008 645-637
	■						450	■	■	2PG 008 645-837
	■						5,000	■	■	2PG 011 422-027
			■				300	■		2PS 008 645-307
			■				1,300	■		2PS 008 645-317
			■				2,000	■		2PS 008 645-367
			■				1,300	■		2PS 008 645-847 ^{C)}
				■			300	■		2PS 008 645-587 ^{B)}
				■			150	■		2PS 008 645-607
				■			300	■		2PS 008 645-617
				■			1,300	■		2PS 008 645-627
				■			1,600	■		2PS 008 645-717 ^{B)}
				■			1,300	■		2PS 008 645-787 ^{D)}
				■			150	■		2PS 008 645-797 ^{D)}
	■						1,300	■		2PS 011 422-077 ^{A)}
	■						450	■		2PS 011 422-267
■	■					1,500	■		2PS 340 912-327	
						■	5,000	■	■	2TM 008 645-947

ELECTRONIC BALLAST

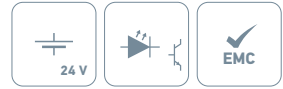

Control electronics for flashing side marker lights

The control electronics are used to comply with ECE R48 Revision 6. All these help as ballast electronics to make conventional side marker lamps flash. Furthermore such electronics conform to legislation as regards existing direction indicator failure controls through evaluation of the rear direction indicator.

Failure monitor: The side marker lights flash together (in phase) with the rear direction indicator light, they obtain their energy from the same supply line. This can lead to a situation where, in the event of a defect in the rear direction indicator, the failure monitor system installed in the towing vehicle no longer functions in accordance with the law and therefore cannot detect a failure. But these control electronics developed by HELLA will ensure the necessary safety. And any defect in the rear direction indicator is reliably detected so that the towing vehicle can inform the driver concerned.

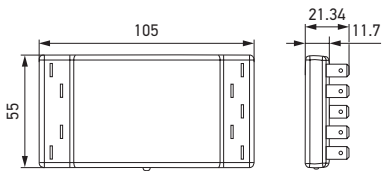

Product picture	Voltage	Connection	Part number
	24 V	6.3 mm flat connector	5DS 223 544-007

ELECTRONIC BALLAST



Distribution for flashing side marker lights

The control unit monitors functioning of the rear direction indicator. In the event of any fault, it switches off the flasher function of the side marker lamps to ensure that the failure control of the towing vehicle conforms to the law. The compact control electronics design permits installation in a distribution box. Only one control unit is required and thanks to the full encapsulation, the control electronics is very robust and watertight. The high degree of EMC protection allows use in very challenging environments. The control electronics is suitable for use with all LED side marker lights.

Flash distributor: System integration directly to main supply line via 15-pin. EasyConn interface.

Sketches

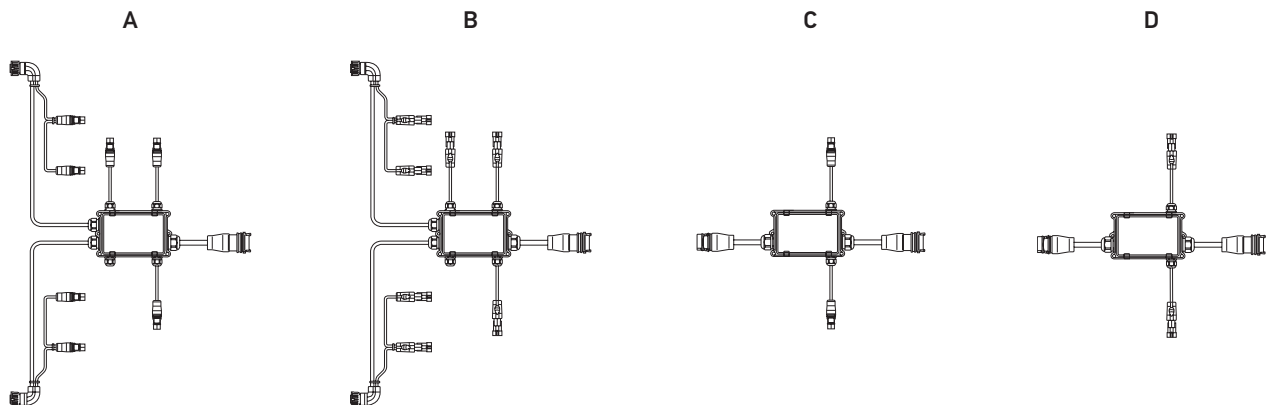

Sketch	Connection	Part number
A	Wired, DIN / EC with two 7-pin outflows. DIN bayonet for connecting the rear combination lamps, 2 EasyConn 2-pin connections each, right and left, for connecting the single-function lamps (KZL, URL), 2 EasyConn 2-pin connections. for flash SMLR right and left and an additional connection 2-pin EasyConn for one reversing light	8JE 340 062-207
B	Wired DIN / SUPERSEAL with two disposals 7-pin DIN bayonet for connecting the rear combination lamps, 2 SUPERSEAL 2-pin connections each, right and left, for connecting the single-function lamps (KZL, URL), 2 SUPERSEAL 2-pin connections. For flash SMLR right and left and also an additional 2-pin connection. SUPERSEAL for one reversing light	8JE 340 062-217
C	Wired, EC / EC, 2 EasyConn 2-pin connections For flash SMLR right and left	8JE 340 062-238
D	Wired, EC / EC, 2 SUPERSEAL 2-pin connections. For flash SMLR right and left	8JE 340 062-247



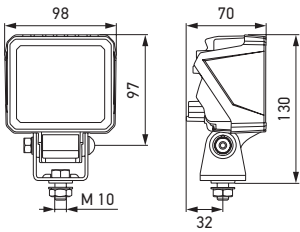

REVERSE LAMPS



EC018 reverse lamp

Die-cast aluminium housing, mounting: upright or pendant (tilt angle 25°), bracket width 42 mm, connection: Cable or DEUTSCH connector.

Light output (measured)	1,350 lumens
Power requirement	18 watts
Colour temperature	5,000 Kelvin
Protection class	IP X9K, IP 6K7

Product picture	Connector type on the light			Cable	Part number
				Length in mm	
	2-pin EasyConn 90°	2-pin SUPERSEAL socket housing	6.3 mm flat receptacles		
	■			1,000	2ZR 996 479-537
	■			3,000	2ZR 996 479-547
			■	3,000	2ZR 996 479-637
		■		1,000	2ZR 996 479-717
		■		2,000	2ZR 996 479-727

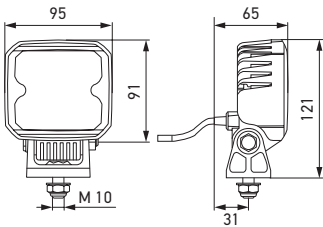

REVERSE LAMPS



Q90 compact LED reverse lamp

With 4 high-power LEDs, multivoltage, mounting: upright (tilt angle 25°), corrosion protection thanks to innovative plastic housing.

Light output (measured)	1,000 lumens
Power requirement	15 watts
Colour temperature	5,000 Kelvin
Protection class	IP 6K9K

Product picture	Connector type on the light		Cable	Part number
	 Open cable ends	 2-pin EasyConn 90°	Length in mm	
	■			2,000
		■	1,800	2ZR 996 284-541

REVERSE LAMPS





Power Beam 1000 reverse lamp

High-quality aluminium housing with CoroSafe coating, mounting: upright or pendant (tilt angle 25°), bracket width 116 mm.

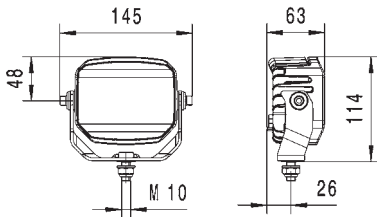
- Light output (measured)** 850 lumens
- Power requirement** 14 watts
- Colour temperature** 6,500 Kelvin
- Protection class** IP 6K9K



Product picture	Connector type on the light	Part number
	 <p>2-pin DEUTSCH pin housing</p>	
		2ZR 996 188-121

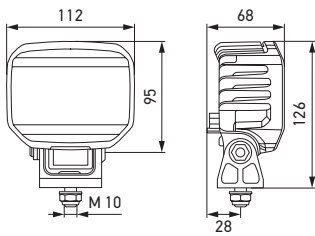

REVERSE LAMPS



Power Beam 1000 compact reversing light

Multivoltage, mounting: upright or pendant (tilt angle 24°), corrosion protection thanks to innovative plastic housing.

Light output (measured)	1,000 lumens
Power requirement	12 watts
Colour temperature	6,500 Kelvin
Protection class	IP 6K9K, IP 6K7

Product picture	Connector type on the light	Part number
	 <p>2-pin DEUTSCH pin housing</p>	
		2ZR 996 188-521

WORK LIGHTS

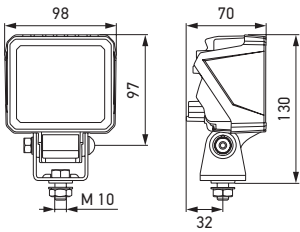

EC018 LED

Multivoltage, polarity reversal protection, overvoltage protection, thermal management, mounting: upright or pendant (tilt angle 25°), ECE R10 approval, high-quality aluminium housing.

Light output (measured)	1,350 lumens
Power requirement	18 watts
Colour temperature	6,500 Kelvin
Protection class	IP 6K9K, IP 6K7

Product picture	Illumination		Connector type on the light		Cable Length in mm	Part number
	Close-range	Long-range	2-pin DEUTSCH pin housing	Open cable ends		
	■			■	500	1GA 996 479-001
		■		■	500	1GA 996 479-011
	■		■		150	1GA 996 479-021
		■	■		150	1GA 996 479-031

WORK LIGHTS





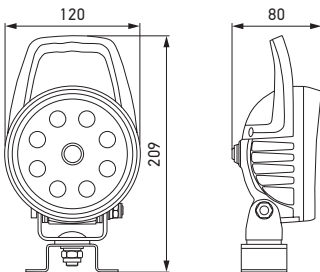

R120S

Die-cast aluminium housing, optimal illumination for work around the vehicle, practical handle, switch for easy on/off handling.

Light output (measured)	1,500 lumens
Power requirement	23 watts
Colour temperature	6,500 Kelvin
Protection class	IP 6K9K, IP 6K7



Product picture	Illumination	Connector type on the light			Cable	Part number
	Close-range	 2-pin EasyConn 90°	 2-pin SUPERSEAL socket housing	 6.3 mm flat receptacles	Length in mm	
	■	■			2,000	1G2 996 220-527
	■			■	1,350	1G2 996 220-607
	■		■		1,300	1G2 996 220-707

AUXILIARY LIGHT

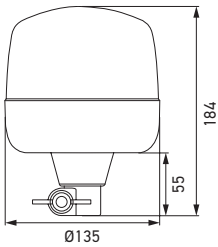





Rota LED beacon

The Rota LED impresses due to its high efficiency, flat and compact design, and the rotating LED light function. The Rota LED is highly robust and extremely efficient. Because of the shock-absorbing rubber foot, it is highly resilient to vibration and thus perfectly suited to challenging fields of application.

Operating temperature	-40 °C to +60 °C
Protection class	IP 5K4K, IP 9K

Product picture	Mounting	Rotating	Part number
	Flexible pipe-socket mounting	■	2RL 010 979-011

Accessories

Product picture	Description	Connector type on the light		Cable	Part number
		 2-pin EasyConn 90°	 2-pin SUPERSEAL socket housing	Length in mm	
	Socket pipe 90°	■		1,300 mm	8HG 340 863-057
	Socket pipe 90°		■	1,300 mm	8HG 340 863-047

AUXILIARY LIGHT

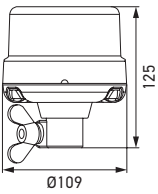





K-LED Nano beacon

Despite its compact dimensions, the K-LED Nano gives out an above-average light intensity. HELLA's smallest homologated beacon to date generates a long-range, amber warning signal by means of flashing light. The shock-absorbing and vibration-damping base briefly tilts the beacon by up to 45° and cushions even strong impacts. Thanks to this option and also to the complete sealing of the beacon, the K-LED Nano can also be used both in vibration-intensive environments and also in dusty ones.

Operating temperature -40 °C to +60 °C
Protection class IP 6K7, IP 6K9

Product picture	Mounting	Flashing	Part number
	Flexible pipe-socket mounting	■	2XD 066 146-011

Accessories

Product picture	Description	Connector type on the light		Cable	Part number
				Length in mm	
	Socket pipe 90°	■			1,300 mm
	Socket pipe 90°			1,300 mm	8HG 340 863-047

AUXILIARY LIGHT

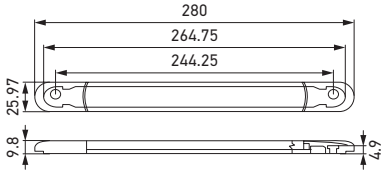

LED auxiliary stop lamp

High-mounted LED stop lamp, with 10 SMD LEDs, suitable for horizontal and vertical mounting, EMC tested.

Protection class IP 5KX, IP X9K

Product picture	Connector type on the light	Cable	Part number
	<p>Open cable ends</p>	Length in mm	
	■	3,000	2DA 343 106-011

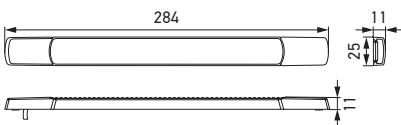

Tail light/stop light

Horizontal / vertical mounting: 360° to lamp and vehicle axis, mounting right and left.

Protection class IP 6K7, IP 6K9K

Product picture	Connector type on the light	Cable	Part number
	<p>Open cable ends</p>	Length in mm	
	■	300	2SB 980 887-211

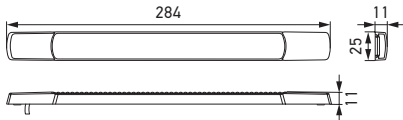

AUXILIARY LIGHT



Tail/Stop light/Indicator

Horizontal / vertical mounting: 360° to lamp and vehicle axis, mounting right and left.

Protection class IP 6K7, IP 6K9K

Product picture	Connector type on the light	Cable	Part number
	 Open cable ends	Length in mm	
	■	2,500	2SD 980 819-201

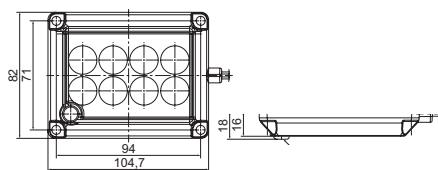



LED interior lamp

Homogeneous illumination with approx. 145 lux in the centre and approx. 125 lux at a distance of 0.6 m from the centre in all directions, crystal-clear polycarbonate lens, screw mounting as surface-mounted variant, particularly suitable for flat mounting conditions (16 mm), multi-voltage circuits keep the light output constant over a voltage range of 10 – 31 V.

Operating temperature -40 °C to +85 °C

Protection class IP 54 (with motion sensor)
IP 67 (without motion sensor)

Product picture	Motion sensor	Connector type on the light	Cable	Part number
		 Open cable ends	Length in mm	
	■	■	2,400	2JA 012 557-007
		■	3,400	2JA 012 557-017

REFLEX REFLECTOR

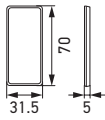

Reflex reflector

Reflex reflector with clear PMMA base plate and self-adhesive tape, dimensions 31.5 mm x 70 mm.

Product picture	Lens	Vertical / horizontal surface mounting	Part number
	Glasklar	■	8RA 004 412-011
	Amber	■	8RA 004 412-007
	Red	■	8RA 004 412-027

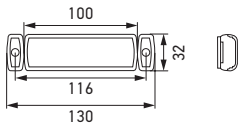

Reflex reflector for rear lamps

Reflex reflector as the SML standard, amber, side-mounted, screw or adhesive mounting depending on the variant

Product picture	Type of mounting	Rear lamp mounting	Part number
	Screw-fastened	For series 340 96x-xx	8RA 011 422-807
	Glued	For series 340-97x-xx	8RA 004 412-007

LEGAL REGULATIONS



Did you know?

HELLA will be happy to advise you on the positioning of the lights on your vehicle. Starting on page 78, you will find an excerpt on the legal regulations for trailers in the following vehicle classes according to ECE Regulation 48:

- O₁** Trailers up to 0.75 t
- O₂** Trailers over 0.75 t up to 3.5 t
- O₃** Trailers over 3.5 t up to 10 t
- O₄** Trailers over 10 t

HELLA accepts no liability for possible deviations from the equipment regulations documented here because of the fact that legal regulations change at irregular intervals.

MAIN POWER SUPPLY CABLE



Main power supply cable

The cables are 2 x 15-pin EasyConn female connector housings, pre-fitted and extrusion-coated. EasyConn receptacle housings assembled and overmoulded. Standard variants are also pre-fitted with the new EasyConn II connector set. The main supply cables are available with and without an additional outlet for the respective braking systems. The design always has a DIN bayonet 4-pin bayonet connector housing. Female connector housing. All cables are ADR tested and approved.

Protection class IP 6K9K

Product picture	Sketch	Connector type			Cable	Wire count	Part number
					Length in mm		
		15-pin EasyConn socket housing overmoulded	15-pin EasyConn socket housing connector set II	4-pin breakout DIN bayonet			
		■		500	15,000	15	8KA 340 817-387
		■		500	10,000	15	8KA 340 817-397
		■		500	15,000	10	8KA 340 817-367
		■		500	10,000	10	8KA 340 817-377
		■			12,000	15	8KA 340 815-027
		■			10,000	15	8KA 340 815-018
		■			14,000	10	8KA 340 816-027
		■			9,000	10	8KA 340 816-007
		■			15,000	8	8KA 340 913-007

FRONT ADAPTER



Front adapter

For semi-trailers and trailers with EasyConn connector housing (15-pin), socket and connector (15-pin DIN ISO 12098) and also 7N and 7S socket and connector (7-pin, ISO 1185 and ISO 3731). However also available in combination with EC, 12098 and 7N/7S.

Suitable for the main supply cables from the series 8KA 340 815-..., 8KA 340 816-... and 8KA 340 817-...

Protection class IP 6K9K

Product picture	Sketch	Connector type						Cable Length in mm	Part number
		Connector	Socket	ISO 12098	7N 1185	7S 3731	ADR (ISO 12098)		
			■	■			■	600	8KA 340 842-007
			■	■			■	1,700	8KA 340 842-017
		■		■			■	3,500	8KA 340 843-007
		■		■			■	6,000	8KA 340 843-027
			■		■	■		1,700	8KA 340 818-007
			■		■	■		600	8KA 340 818-017
		■			■	■		3,500	8KA 340 841-007
		■			■	■		6,000	8KA 340 841-037
			■	■	■	■		600 + 300	8KA 340 886-027
			■	■	■	■		600 + 800	8KA 340 886-077

FRONT DISTRIBUTOR



Front distributor

For semi-trailers and a direct connection to the EasyConn system, with 3 combined sockets (1 x socket DIN ISO 12098, 1 x 7-N socket DIN ISO 1185, and 1 x 7-S socket DIN ISO 3731) and 1 EasyConn plug connection (15-pin for the main supply, 500 mm), or available with PG screw connection.

Protection class IP 6K9K

Product picture	Sketch	Connector type			Cable	Part number
		ISO 12098	7N 1185	7S 3731	Length in mm	
		■	■	■	500	8JE 340 898-107
		■	■	■	-	8JE 340 898-117

Accessories

Product picture	Description	Part number
	Sealing cap for 7N / 7S on front box Necessary for ADR-approved vehicles	9HV 233 194-007

REAR ADAPTER



Rear adapter

Rear adapter cable with EasyConn connector housing (15-pin). Suitable for the main supply cables from the series 8KA 340 815-..., 8KA 340 816-..., and 8KA 340 817-...

Protection class IP 6K9K

Sketch	Connector type on the cable			Connector type / breakout			Cable	Part number
							Length in mm	
	■			6x 500			1300/1300	8KA 340 819-007
	■			4x 500			1300/1300	8KA 340 819-017
	■			6x 500			2000/2000	8KA 340 819-067
	■		■	2x 1,000			3000/3000	8KA 340 819-127
	■		■			2x 17,000	1300/1300	8KA 340 819-157
	■		■				1500/2500	8KA 340 819-197
		■	■				2,000 / 2,500	8KA 340 819-477
		■		6x 500			2,000 / 2,000	8KA 340 819-467
		■	■				2,000 / 2,000	8KA 340 819-427
		■			6x 500		2,000 / 2,000	8KA 340 819-437

CHAINS



SMLR chains

Our SMLR chains and supply cable to connect side marker lights with reflex reflector and position lights with EasyConn or SUPERSEAL.

Protection class IP 6K9K

Sketch	Connector type			Signal and sundry lamps	Part number
				Number	
	■			5	8KB 340 820-257
	■			4	8KB 340 820-327
	■			6	8KB 340 820-277
	■			8	8KB 340 820-297
		■		5	8KB 340 820-427
		■		4	8KB 340 820-397
		■		8	8KB 340 820-437
			■	8	8KB 340 927-027
			■	5	8KB 340 927-017
			■	4	8KB 340 927-007







CABLES



SMLR supply line

Our SMLR chains and supply cable to connect side marker lights with reflex reflector and position lights with EasyConn, SUPERSEAL or via quick link indentation clamping technology.

Protection class IP 6K9K

Sketch	Connector type			Cable	Part number
	 2-pin EasyConn socket housing	 2-pin EasyConn 90°	 2-pin SUPERSEAL socket housing	Length in mm	
	■			15,000	8KA 340 822-067
	■			10,000	8KA 340 822-087
	■			21,000	8KA 340 822-007
		■		16,000	8KA 340 822-207
		■		9,000	8KA 340 822-217
		■		21,000	8KA 340 822-227
			■	8,000	8KA 340 038-208
			■	12,000	8KA 340 038-228
			■	16,000	8KA 340 038-247

CABLES

**Flat cable**

Flat cable FLYYF, suitable for Quick Link connections.

Sketch	Number of cores	Cross-section	Cable	Part number
			Length in mm	
	2	2 x 1.5 mm ²	100,000	8KL 340 050-001

**Round cable**

Round cable FLRY, without plug connection for individual system connection, sold by the metre, various cable lengths on request, connectors and service sets from page 47 onwards

Sketch	Number of cores	Cross-section	Part number
	2	2 x 1.0 mm ²	8KL 340 009-00*
	2	2 x 0.5 mm ²	8KL 340 055-02*
	4	4 x 1.0 mm ²	8KL 340 403-01*
	7	6 x 1.0 mm ² / 1 x 1.5 mm ²	8KL 340 412-00*
	7	4 x 1.5 mm ² / 2 x 2.5 mm ²	8KL 340 054-00*
	10	8 x 1.0 mm ² / 2 x 2.5 mm ²	8KL 340 093-01*
	15	12 x 1.0 mm ² / 3 x 2.5 mm ²	8KL 340 059-00*

* Cable length on request.

ADAPTER



Adapter lead

Round cable FLRYY with open end and Quick Link connector including clamping piece.

Protection class IP 6K9K

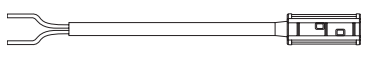

Sketch	Connector type	Cable	Part number
	 2-pin Quick link	Length in mm	
	■	500	8KA 998 229-017



Adapter lead

Round cable FLRYY with open end, SUPERSEAL and/or EasyConn connection.

Protection class IP 6K9K

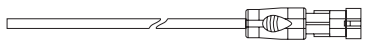
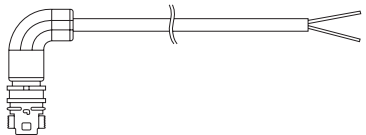
Sketch	Connector type	Cable	Part number
	 2-pin SUPERSEAL pin housing	Length in mm	
	 2-pin EasyConn 90°		
	■	6,000	8KA 340 954-007
	■	6,000	8KA 340 854-107

ADAPTER

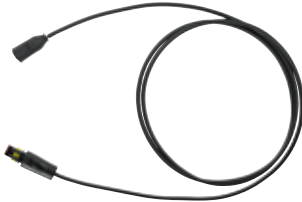

Adapter lead

Round cable FLRYY with open end, SUPERSEAL, EasyConn and DEUTSCH connection.

Protection class IP 6K9K

Sketch	Connector type					Cable	Part number
						Length in mm	
	■	■				2,000	8KA 340 038-131
		■	■			2,000	8KL 340 038-117
		■		■		1,300	8KA 340 854-127
			■		■	150	8KA 340 854-227



Adapter lead

Round cable FLRYY as intermediate adapter with 15-pin EasyConn connection.

Protection class IP 6K9K

Sketch	Connector type		Cable	Part number
			Length in mm	
	■	■	500 (2x)	8KA 340 864-017

ADAPTER



Adapter lead

Round cable FLRYY as intermediate adapter / extension with SUPERSEAL or EasyConn connection, 2-pin, 1.0 mm²

Protection class IP 6K9K

Sketch	Connector type					Cable	Part number
						Length in mm	
	■	■				150 (2x)	8KA 340 859-007
	■	■				150 (2x)	8KA 340 859-017
				■	■	150 (2x)	8KA 340 859-027
		■	■			150 (2x)	8KA 340 859-037
				■	■	150 (2x)	8KA 340 859-047
				■	■	3,000	8KA 340 038-107
				■	■	4,000	8KA 340 038-377

ADAPTER



Adapter lead

Adapter cable for tail lamp, EasyConn to DIN bayonet, 7-pin.

Protection class IP 6K9K

Sketch	Vehicle side	Connector type		Cable	Part number
				Length in mm	
	Right	■	■	500	8KA 340 826-267
	Left	■	■	500	8KA 340 826-277



Shapeline adapter cable

Wiring harness for Shapeline rear lighting, SUPERSEAL outputs for individual light functions (e.g. direction indicators, stop light, tail light).

Protection class IP 6K9K

Sketch	Connector type				Cable	Part number
					Length in mm	
	■	■	■		450 (4x)	8KA 340 159-007
	■	■	■		450 (4x)	8KA 340 159-027
	■	■		■	450 (3x)	8KA 340 159-037
	■		■	■	450 (3x)	8KA 340 159-047

DISTRIBUTORS



Distributor box

Distributor box with ten M16 and two M25 screwed cable glands, two cables with an EasyConn connector housing and an EasyConn female connector housing, fully assembled on the plug board.

Protection class IP 6K9K

Sketch	Connector type		Cable	Part number
			Length in mm	
	15-pin EasyConn connector housing	15-pin EasyConn socket housing		
	■	■	500 (2x)	8JE 340 847-007



Distributor box

Distributor box with seven PG 9, seven PG 13.5 and two PG 21 screwed cable glands, two cables with an EasyConn connector housing and an EasyConn female connector housing, fully assembled on the plug board.

Protection class IP 6K9K

Sketch	Connector type		Cable	Part number
			Length in mm	
	15-pin EasyConn connector housing	15-pin EasyConn socket housing		
	■	■	300 mm (2x)	8JE 340 867-057

BATTERY BOX



PS-Fix "Park Safety Fix"

24 V battery box for self-sufficient power supply of trailers enables control of lighting even when trailer is uncoupled, safe loading and unloading even without towing vehicle, increased warning effectiveness for parked trailers, also 6-point screw fastening to the left / right on the housing for direct mounting on trailer frame

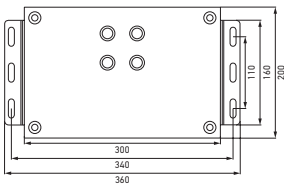

Protection class IP 54

Product picture	Description	ADR certification	Part number
	PS-Fix Box, standard		8EN 340 355-001
	PS-Fix Box with ADR certification	■	8EN 340 355-201

Sketch

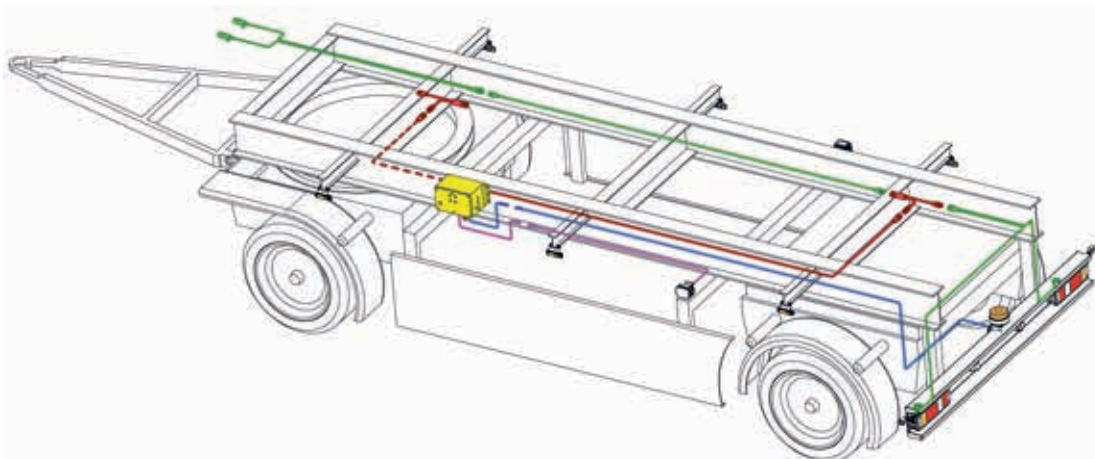

CONNECTOR SETS



SUPERSEAL plug housing set

SUPERSEAL plug connectors comply with IEC 529 regulations and DIN ISO 40050, and come with protection class IP 67, which offers the maximum level of water and dust proofing. Where other interconnection systems reach their limits due to adverse pressure or humidity conditions, SUPERSEAL is ideally suited.

Protection class IP 67

Product picture	Description	Number of cores	Connector type		Part number
			Buchse	Pin	
	SuperSeal connector socket housing, 2-pin, with single wire seal and contacts	2	■		9XX 744 806-812
	SuperSeal connector pin housing, 2-pin, with single wire seal and contacts	2		■	9XX 744 806-822
	SuperSeal connector socket housing, 4-pin, with single wire seal and contacts	4	■		9XX 744 806-832
	SuperSeal connector pin housing, 4-pin, with single wire seal and contacts	4		■	9XX 744 806-842



EasyConn connector / socket

EasyConn repair set 2, 7 and 15-pin. for socket housings and connector housings.

Sketch	Description	Diameter	Part number
	With EasyConn female connector housing (2-pin) (Mating connector for 2-pin EasyConn connector housing)	19.5 mm	9XX 340 879-007
		24.5 mm	9XX 340 882-007
	With EasyConn female connector housing (7-pin) (Mating connector for 7-pin EasyConn connector housing)	28.0 mm	9XX 340 880-007
		33.0 mm	9XX 340 883-007
	With EasyConn female connector housing (15-pin) (Mating connector for 15-pin EasyConn connector housing)	39.0 mm	9XX 340 981-001
		44.0 mm	9XX 340 984-001

PLUG SETS



Sealing plug

For connector housing, designed for airtight sealing of not required EasyConn connector housing with an O-ring.

Product picture	Sketch	Description	Part number
		Sealing plug for 2-pin Connector housing	9XX 340 870-007
		Sealing plug for 7-pin Connector housing	9XX 340 871-007
		Sealing plug for 15-pin Connector housing	9XX 340 872-007



Cap

For SUPERSEAL connector and socket housing, 2-pin. and also EasyConn socket housing, 2-pin

Product picture	Sketch	Description	Part number
		Cap/sealing plug for 2-pin SUPERSEAL connector and socket housing	9XX 340 814-017
		Cap for 2-pin EasyConn socket housing	9HV 340 812-007

FUSE SETS



Fuse set

For the additional securing of EasyConn plug connectors under a high tensile load with mechanical seal and union nut.

Product picture	Sketch	Description	Part number
		Fuse set for 2-pin EasyConn connection	9XX 340 876-007
		Fuse set for 7-pin EasyConn connection	9XX 340 877-007
		Fuse set for 15-pin EasyConn connection	9XX 340 878-007

Accessories for Quick Link connection

Product picture	Description	Part number
	Quick link clamping piece	8KW 998 602-002
	Heat-shrink end caps up to max. 11 mm	9GS 340 051-011
	"Quick Link" hand crimping tool Special Quick Link crimping pliers, suitable for the 2-pin "click-in" contact system	8PE 008 932-001



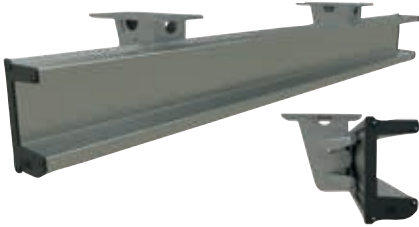

UNDERRIDE GUARD







Underride guard

Robust aluminium underride guard in accordance with UNECE R58-03 for trucks (N2 and N3 > 3.5 t) and trailers (O3 and O4 > 3.5 t) for a high degree of road safety, can be used for several track widths thanks to flexible mounting position, various hole patterns ensure maximum modular freedom

① As of September 1, 2021 an underride guard in accordance with UNECE R58-03 is mandatory for all newly homologated trucks (N2 and N3 > 3.5 t) and trailers (O3 and O4 > 3.5 t)!

Hole pattern milling	Track width	Part number
	750 mm – 1,400 mm	9XX 340 384-001
	1,100 mm – 1,400 mm	9XX 340 384-011
	1,200 mm – 1,400 mm	9XX 340 384-021
	950 mm – 1,400 mm	9XX 340 384-031

① In order to comply with the new legal regulation UNECE R58-03, it is mandatory to have brackets to secure the underride guard to a vehicle. You have the option of choosing between tall and short brackets.

Product picture	Description	Part number
	Bracket left, short (352 mm)	9XX 340 383-011
	Bracket right, short (352 mm)	9XX 340 383-021
	Bracket left, tall (582 mm)	9XX 340 383-031
	Bracket right, tall (582 mm)	9XX 340 383-041

UNDERRIDE GUARD





Mounting examples



Application example



ACCESSORIES

Product picture	Designation	Description	Part number
	<p>EC spray EasyConn spray</p>	<p>EasyConn spray, assembly lubricant, corrosion and humidity protection for electronics and metal.</p>	<p>9XH 340 730-007</p>
	<p>Protection cap Modular rear combination lamp</p>	<p>Cover for rear combination lamps.</p>	<p>8XS 340 092-017</p>
	<p>MTL lenses Lens with screws</p>	<p>Lens - modular rear combination lamp, can be used on left and right</p>	<p>9EL 183 432-001</p>
	<p>Lens round lamp Lens</p>	<p>Lens round lamp, can be used on left and right.</p>	<p>9EL 213 522-001</p>
	<p>Chrome ring set Set (3 pieces)</p>	<p>Contains chrome ring, seal and U-holder.</p>	<p>9XD 997 909-811</p>



LED INDICATORS AND FAILURE CONTROL FROM HELLA. NOW ADOPTED IN ISO 13207-1 – FOR 24-V TRUCKS, TRAILERS AND OTHER VEHICLES WITH A 24-V VEHICLE ELECTRIC SYSTEM

Legal requirement in all ECE states

In the case of vehicles registered for public road traffic, it is imperative that the direction indicators are monitored: failure of a direction indicator must be communicated to the vehicle's driver visually or acoustically. This applies to all ECE states in which regulation ECE R 48 is in effect. This means possible indicator failure must be monitored by the vehicle. Manufacturers use different procedures for this.

The failure monitors currently in use cannot detect simple LED lamps and thus indicate a fault. Many HELLA LED indicators have integrated failure control electronics. The indicator lights are self-monitoring. When functioning correctly, they create a pulse according to ISO 13207-1 which can be evaluated by the vehicle electronics. If the available vehicle electronics cannot evaluate the pulse themselves, Hella provides various solutions for evaluating this pulse, shown below.

As soon as one single LED fails, the lamp is shown as faulty and the pulse will no longer be generated. In such a case the ballast then switches off the bulb simulation and the flasher unit reports the error to the driver.

Safe conversion to LED direction indicators using HELLA electronics in accordance with ISO 13207-1

As indicators must be checked by law, we recommend operating the lights only in conjunction with a failure control according to ISO 13207-1.

For LED direction indicators with a control pulse, HELLA offers electronic ballasts which make it possible to display direction indicator failure for various vehicle assemblies and modifications. This is necessary if the vehicle manufacturer does not guarantee direction indicator failure control via the vehicle's electrical system.

There are three different ballasts and several different LED direction indicators available:

As a new solution, HELLA recommends detecting the electrical pulse directly in the vehicle manufacturer's vehicle electric system.

It is merely necessary to integrate the check according to ISO 13207-1. This means that you no longer have to rely on interim solutions using direction indicator control units.

LED LAMP CONTROL UNIT



Control unit

The control unit is only responsible for monitoring the direction indicators.

Protection class IP 6K9K



Sketch	Description	Part number
	<p>24 V standard control unit with 15-pin EasyConn connection</p>	<p>5DS 009 552-081</p>
	<p>24 V standard control unit with 6.3 mm flat receptacle</p>	<p>5DS 009 552-101</p>



Control unit

Control unit, 24 volts, for monitoring all functions (rear combination lamp).

Protection class IP 6K9K

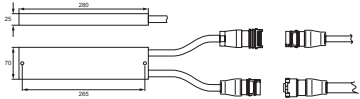
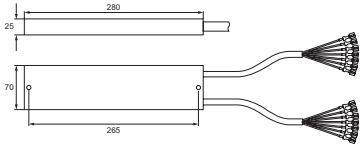
Sketch	Connector type			Cable	Part number
	 15-pin EasyConn connector housing	 15-pin EasyConn socket housing	 6.3 mm flat receptacles	Length in mm	
	■	■		1,300 (2x)	5DS 009 552-047
			■	1,500 / 300	5DS 009 552-037

QUALITY TESTS

Proven quality from HELLA

Heat, long hours in operation, impacts and knocks. The working conditions of work lights impose great demands. Which explains why all HELLA work lights are tested to the highest standards of quality throughout development and manufacture. This enables you to deliver optimum performance.



IP PROTECTION CLASSES EXPLAINED

What does IP protection category mean?

IP stands for International Protection. The IP protection classes are determined in accordance with DIN 40 050, Part 9. The purpose of the standard is to establish exactly the state of the electrical equipment of vehicles as regards the ingress of solid foreign objects including dust and also as regards the ingress of water. The different degrees of protection important for signaling systems are explained below.

Protection class IP 5K4K

Dust may only penetrate to such an extent that the function and safety are not impaired. Water that is sprayed against the housing from any and every direction at increased pressure must not have any damaging effect: water pressure approx. 4 bar.

Protection class IP 5K9K

Dust may only penetrate to such an extent that function and safety are not impaired. Water that is directed against the housing during high-pressure/steam-jet cleaning must not have any damaging effect; water pressure approx. 100 bar.

Protection class IP 67

Dust must not penetrate. Even during temporary immersion, no water is to penetrate.

Protection class IP 6K4K

Dust must not penetrate. Water that is sprayed from every direction at increased pressure against the housing must not have any damaging effect: water pressure approx. 4 bar.

Protection class IP 6K7

Dust must not penetrate. Even during temporary immersion, no water is to penetrate. HELLA products meet the highest requirements and are optimally protected against all weather conditions.

Protection class IP 6K9K

Dust must not penetrate. Water that is directed against the housing during high-pressure/steam-jet cleaning must not have any damaging effect; water pressure approx. 100 bar.

Protection class IP 9K

Water that is directed from high-pressure/steam-cleaning equipment onto the housing must not have any damaging effect: water pressure approx. 80 – 100 bar.

IP 6K9K

First digit: protection against the ingress of foreign bodies (see Table 1).

Second digit: protection against the ingress of water (see Table 2).

K: Denotes tests for equipment of road vehicles.

Protection against the ingress of foreign bodies (incl. dust)

X	not tested
0	no special protection
1	solid foreign bodies, diameter ≥ 50 mm
2	solid foreign bodies, diameter ≥ 12.5 mm
3	solid foreign bodies, diameter ≥ 2.5 mm
4	solid foreign bodies, diameter ≥ 1.0 mm
5K as 5	dust-proof
6K as 6	dust-proof

Chart 1

Protection against the ingress of water

X	not tested
0	no special protection
1	vertically falling drops of water
2	drops of water falling at 15° angle
3	water dropping up to an angle of 60°
4	drops of water from all directions
4K	same as 4 but at increased pressure
5	water jet from a nozzle
6	identical to 5 but at increased pressure
7	temporary immersion in water
8	sustained immersion in water
9K	cleaning under extremely high pressure

Chart 2

ICON OVERVIEW



Vehicle electrical system voltage

Defines the power supply of the light. This can be 12 V, 24 V or a flexible voltage range for multi-voltage (e.g. 8 – 33 V).



Operating temperature

Thermal management and an optimised housing design guarantee full functioning for all operating temperatures as a result of product testing ranging from -40 °C to +60 °C.



Dust and water protection class - IP

International Protection (IP) in accordance with DIN 40050, Part 9. Specific definition for road vehicles:

First digit:

protection against dust and dirt
5K = Dust protected
6K = Dustproof

Second digit:

Protection against water
4K = Protection against splashing water from any direction with increased pressure
7 = Protection against temporary immersion
9K = Protection against water during high pressure/steamjet cleaning

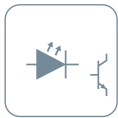

Active

Electronic circuit

Basically, two different circuits are possible for LED lamps.

Active (AE):

LED current control by means of active electronics



Passive

Passive (PT):

Setting a specific voltage range for the LED by means of a series resistor



Active

Thermal management

Active:

Electronic power control of the LEDs when high ambient temperatures exceed permitted levels. This ensures that LEDs are protected against destruction caused by overheating.



Passive

Passive:

Optimal layout of components for even temperature distribution and temperature spread



Overvoltage protection

Supplement to the electronics for protecting the LED against high voltage / current in the vehicle's electric system as per ISO 7637-2.

Overloading of the LEDs can be caused by increased voltage peaks in vehicles as a result of the following:

- Jump-starting
- Faulty control units
- Load dump pulses (faulty battery contact)

Such peaks stress/damage the LEDs, which can lead to function failure or to a reduction in lifetime. Complementing the circuit with appropriate components protects the circuit and can extend the lifetime or even prevent failure.



Bipolarity of the lamps

Even if the connecting cable is fitted the wrong way round, everything still functions fully.

The semiconductor in an LED must always be operated with the specified polarity only. Incorrect polarity will damage the LED so for that reason LED lamps are generally equipped with polarity reversal protection (diode). However, this function only works if "+" and "-" are connected correctly. If a lamp has a bipolar circuit, its functioning is independent of the contact connections. This then ensures that poka yoke (avoidance of faulty mounting) is present in connection with, for example, indentation clamping technology. However, the additional components on the printed circuit board increase the cost outlay.



Polarity reversal protection

Even if the connecting cable is fitted the wrong way round, there is still no danger for the electronics



Electromagnetic compatibility

Electromagnetic compatibility (EMC) tested and EU type approval issued.

If the lamp is not designed and constructed according to EMC specifications, and thus is not certified, then interactions between it and other safety-relevant electronic systems may occur.



Integrated short-circuit fuse

Protected against short circuit by means of an amp fuse.



Approved for dangerous goods transports

Lamp approved for transport of dangerous goods according to the European Agreement Concerning the International Carriage of Dangerous Goods by Road (ADR; in German, GGVS).



Direction indicator failure control in accordance with ECE R48

Regulation according to ECE-R48:

The driver must be informed if the vehicle's direction indicator function fails. In order to remain legally compliant, this requirement must also be met for LED direction indicators. Such a requirement is met by means of an integrated self-diagnosis system on the printed circuit board of the LEDs and with an electrical pulse. Since the end of 2011, this HELLA failure control with pulse has been an ISO standard: ISO 13207.

If the direction indicator failure control cannot be guaranteed, the General Certification for a vehicle expires. Therefore it is not permitted to operate vehicles without a direction indicator failure control in countries subject to ECE R48.



Automotive Electronic Council

Components qualified according to automotive standard. Electronic components (LEDs, diodes, etc.) governed by automotive specifications are more robust and safer than electronic components designed for industry.



Automotive Safety Integrity Level

Product electronics are developed using cutting-edge methods and in accordance with the ISO 26262 safety guideline.



ECE

This product is tested in line with ECE guidelines.

Further information about the ECE certification symbols can be found on the relevant products.



SAE

Product has SAE type approval.



PLUG CONNECTIONS AND PIN ASSIGNMENTS

7-PIN CONNECTOR SYSTEM COMPLIANT WITH ISO 11 85 (N-TYPE)

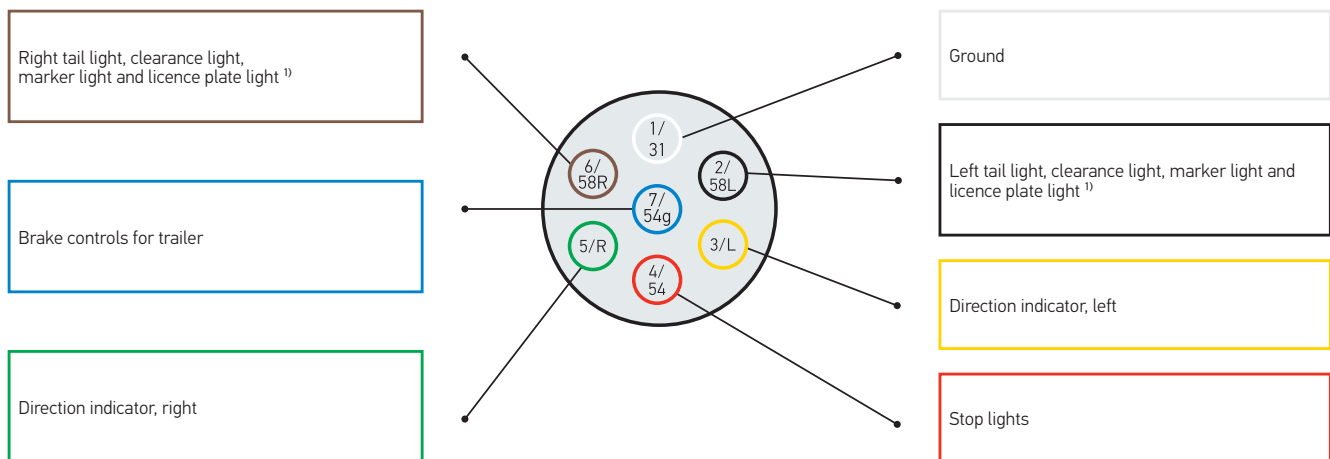

Assignment diagram – trailer connector fitting, 24 Volt / 7-pin N type ISO 1185
31 contact/socket – pin; 31 contact/connector – sleeve

Contact assignment for normal plug-type connectors in accordance with ISO 1185, 24 V, 7-pin N

Contact no.	Function	Cable cross-section	Colour and core isolation
1/31	Ground	2.5 mm ²	□
2/58L	Left tail light, clearance light, sidelight and licence plate lighting ¹⁾	1.5 mm ²	■
3/L	Direction indicator, left	1.5 mm ²	■
4/54	Stop lights	1.5 mm ²	■
5/R	Indicator, right	1.5 mm ²	■
6/58R	Right tail light, clearance light, sidelight and licence plate lighting ¹⁾	1.5 mm ²	■
7/54g	Trailer brake controller	1.5 mm ²	■

¹⁾ The licence plate lighting must be connected in such a way that none of its lamps are connected to the two contacts 2 and 6.

7-PIN CONNECTOR SYSTEM COMPLIANT WITH ISO 37 31 (S-TYPE)

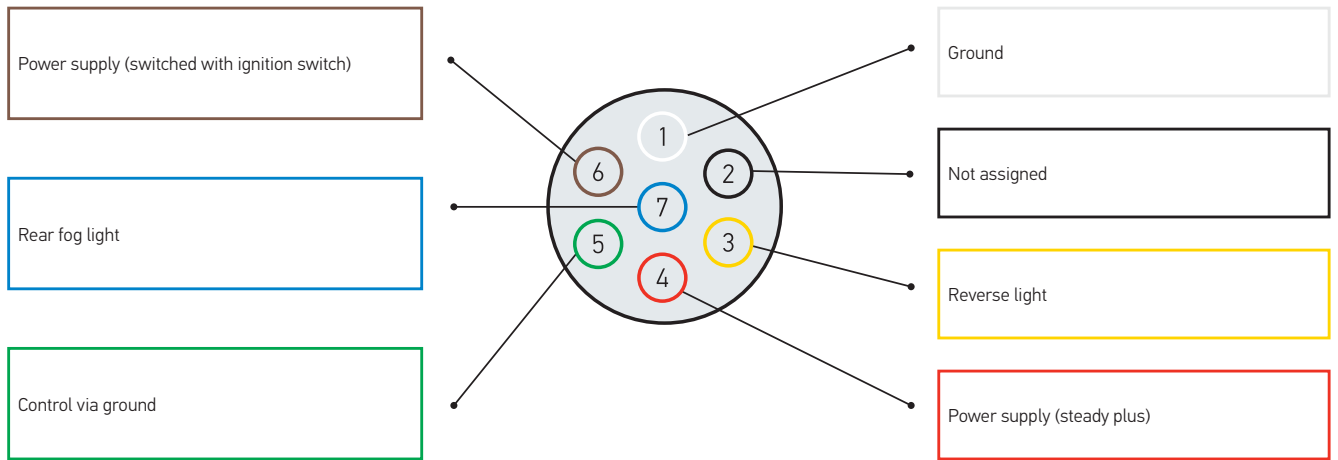

Assignment diagram – trailer connector fitting, 24 Volt / 7-pin S type ISO 3731
31 contact/socket – sleeve; 31 contact/connector – pin

Contact assignment for auxiliary plug-type connectors in accordance with ISO 3731, 24 V, 7-pin S

Contact no.	Function	Cable cross-section	Colour and core isolation
1	Ground	2.5 mm ²	□
2	Reserved for future applications	1.5 mm ²	■
3	Reverse light	1.5 mm ²	■
4	Power supply (steady plus)	2.5 mm ²	■
5	Control via ground	1.5 mm ²	■
6	Power supply via the ignition switch	2.5 mm ²	■
7	Rear fog light	1.5 mm ²	■

TRAILER CONNECTOR FITTING, 15-PIN IN ACCORDANCE WITH ISO 12098

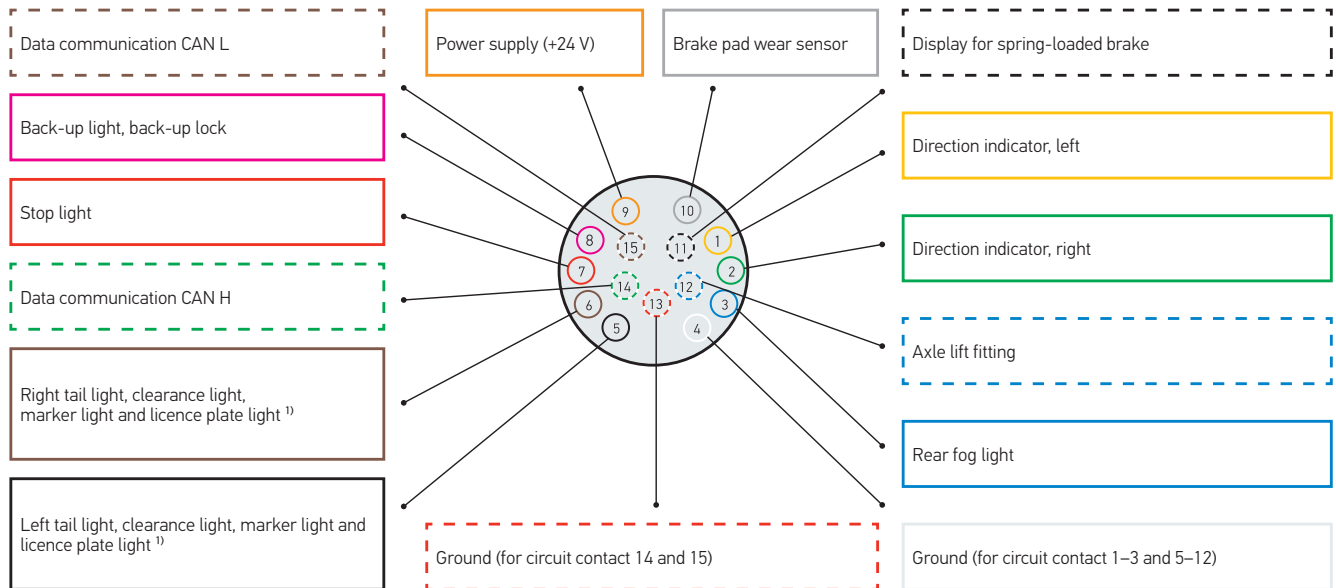

Contact assignment for plug-type connectors in accordance with ISO 12098, 24 V, 15-pin

Contact no.	Function	Ø cable	Colour and core isolation
1	Direction indicator, left	1.5 mm ²	
2	Direction indicator, right	1.5 mm ²	
3	Rear fog light	1.5 mm ²	
4	Ground for contacts 1-3 and 5-12	2.5 mm ²	
5	Left tail light, clearance light, sidelight and licence plate lighting ¹⁾	1.5 mm ²	
6	Right tail light, clearance light, sidelight and licence plate lighting ¹⁾	1.5 mm ²	
7	Stop lights	1.5 mm ²	
8	Reverse light	1.5 mm ²	
9	Permanent power supply (24 V)	2.5 mm ²	
10	Sensor for brake pad wear indication	1.5 mm ²	
11	Display for spring-loaded brake	1.5 mm ²	
12	Axle lift	1.5 mm ²	
13	Ground for data cables 14 and 15	2.5 mm ²	
14	CAN H	1.5 mm ²	
15	CAN L	1.5 mm ²	

¹⁾ The licence plate lighting must be connected in such a way that none of its lamps are connected to the two contacts 5 and 6.

FREE INFO AND TOOLS ON THE NET



Website trailer

Informative, compact, interactive. Here you can find everything you need to know about products and technologies for commercial use.

www.hella.com/trailer



ELIVER - the light comparison tool

This online tool allows you to compare many HELLA work lamps and beacons on the basis of their illumination in a real-world environment.



 www.hella.com/eliver



HELLA Shapeline – design your light

The variety and range of shapes and various combination options paired with a technically optimised product design make the Shapeline lamp series a true innovation in vehicle lighting.



LEGAL REGULATIONS

For trailers in accordance with ECE Regulation 48

Vehicle classes:

- O₁** Trailers up to 0.75 t
- O₂** Trailers over 0.75 t up to 3.5 t
- O₃** Trailers over 3.5 t up to 10 t
- O₄** Trailers over 10 t

HELLA accepts no liability for possible deviations from the equipment regulations documented here because of the fact that legal regulations change at irregular intervals.

Front lighting

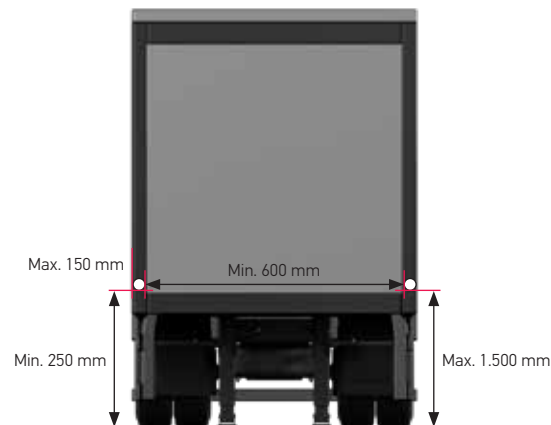

Position lamps

ECE-R48 section 6.9 and ECE-R7 or ECE-R148

Presence ECE-R48 § 6.9.1	Mandatory for all trailers > 1.6 m wide. Approved for trailers ≤ 1.6 m wide.
Number ECE-R48 § 6.9.2	Two lamps
Color ECE-R48 § 5.15	White
Position in width ECE-R48 § 6.9.4.1	Max. 150 mm from the extreme outer edge of the vehicle. Min. 600 mm between both position lamps, but min. 400 mm for vehicle widths < 1,300 mm.
Position in height ECE-R48 § 6.9.4.2	Min. 250 mm, max. 1,500 mm (exception: 2,100 mm only for trailers in classes O1 and O2 or if max. 1,500 mm is not possible for other trailers).
Visibility ECE-R48 § 6.9.5	Horizontal 5° inwards and 80° outwards. Vertical ± 15°, but for a position in height of < 750 mm also 5° downwards.
Electrical connections ECE-R48 § 6.9.7	Must be designed so that the position lamp, tail lamp, side marker lamps and registration plate lamps can only be switched on and off simultaneously. Can be switched off when indicating.
Tail-tale ECE-R48 § 6.9.8	Prescribed. The indicator lamp may not flash. Not necessary if the lighting equipment in the dashboard can only be switched on at the same time as the position lamps.



Reflectors (non-triangular)

ECE-R48 section 6.16 and ECE-R3 or ECE-R150

Presence ECE-R48 § 6.16.1	Prescribed for all trailers.
Number ECE-R48 § 6.16.2	Min. two devices, further two optional
Color ECE-R48 § 5.15	White or colorless
Position in width ECE-R48 § 6.16.4.1	Max. 150 mm, min. 600 mm between both reflex reflectors, but min. 400 mm for vehicle widths < 1,300 mm.
Position in height ECE-R48 § 6.16.4.2	Min. 250 mm, max. 900 mm (exception: 1,500 mm).
Visibility ECE-R48 § 6.16.5	Horizontal 10° inside and 30° outside. Additional reflex reflectors can help with the horizontal values. Vertical ± 10°, but for a position in height of < 750 mm 5° downwards.
Form ECE-R48 § 6.16	Not triangular
Other regulations ECE-R48 § 6.16.7	The illuminating surface of the retro-reflector may have parts in common with the apparent surface of any other lamp situated at the front.

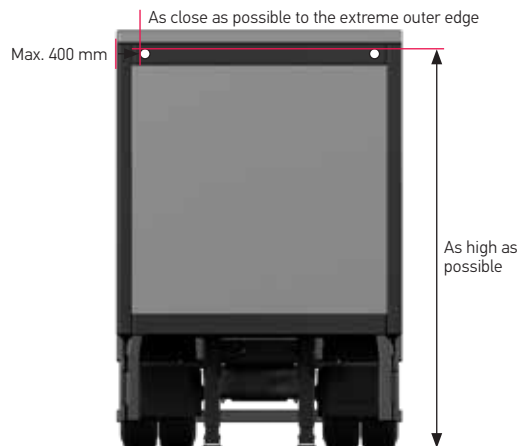

End-outline markers/ Clearance lamps

ECE-R48 section 6.13 and ECE-R7 or ECE-R148

Presence ECE-R48 § 6.13.1	Mandatory for trailers > 2.1 m wide. Optional for trailers > 1.8 m ≤ 2.1 m width. Categories A or AM – visible from the front.
Number ECE-R48 § 6.13.2	Two visible from the front. Optional additional lamps: two visible from the front.
Color ECE-R48 § 5.15	White in front
Position in width ECE-R48 § 6.13.4.1	Max. 400 mm from the extreme outer edge of the vehicle.
Position in height ECE-R48 § 6.13.4.2	As high as possible. Maximum distance to optional lamps.
Position in length UN-R48 § 6.13.4.3	If additional lamps to the front are installed they shall be placed as close to the rear as possible, max. 400 mm distance from the rear.
Visibility ECE-R48 § 6.13.5	Horizontal 80° to the outside, vertical 5° over and 20° below the horizontal plane.
Electrical connections ECE-R48 § 6.13.7	Must be designed so that the position lamp, tail lamp, side marker lamps and registration plate lamps can only be switched on and off simultaneously.
Tell-tale ECE-R48 § 6.13.8	Approved. If there is a tell-tale, its function must be satisfied by the mandatory tell-tale for the position lamps and tail lamps. However, a tell-tale indicating failure is mandatory if required by the component regulation.
Other regulations ECE-R48 § 6.13.9	The front white end-outline marker lamps may be combined in one lamp as long as the installation instructions and visibility values are satisfied. Distance to position lamp min. 200 mm. The additional lamps visible from the front, used to mark the rear end outline of the trailer or the semi-trailer shall be fitted in such a way to make it visible within the fields of vision of the approved main rear-view devices for indirect vision.

Side lighting

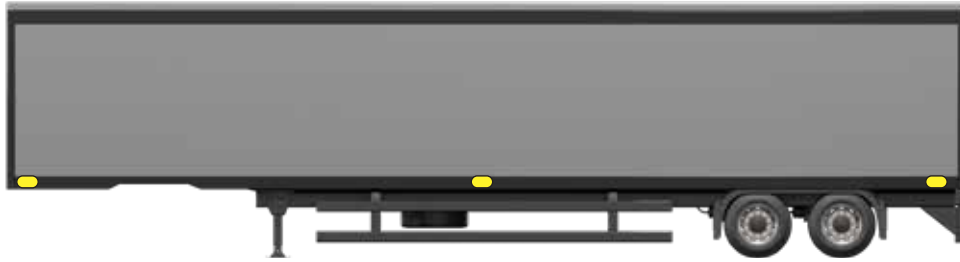

Direction indicators

ECE-R48 section 6.5 and ECE-R6 or ECE-R148

Presence ECE-R48 § 6.5.1	Mandatory for O3 and O4 vehicles exceeding 9 m in length. Optional for O2 vehicles exceeding 9 m in length.
Number ECE-R48 § 6.5.3.1	According to the arrangement "B": max. three optional category 5 or one optional category 6 device per side on vehicles of type O2 exceeding 9 m in length. Three (on each side of the vehicle) category 5 mandatory for O3 and O4 exceeding 9 m in length. These requirements do not apply if there are at least three amber side marker lamps that flash in phase and simultaneously with the direction indicator lamps on the same side of the vehicle.
Color ECE-R48 § 5.15	Amber
Position in height ECE-R48 § 6.5.4.2.1	Min. 500 mm, max. 1,500 mm (exception: 2,300 mm)*. * An exception is only possible if the vehicle geometry does not make standard installation possible.
Position in length ECE-R48 § 6.5.4.3	Max. 1,800 mm from the front, measured from the outermost point. 2,500 mm if the structure requires this.
Visibility ECE-R48 § 6.5.5	Horizontal min. 5° to 60° rear. Vertical ± 15° for category 5, but for position in heights of < 750 mm also 5° downwards. For category 6, however, 30° over and 5° below the horizontal.
Electrical connections ECE-R48 § 6.5.7	Prescribed. Must switch on with the direction indicators on the same side of the vehicle together and independently of the other lamps. They need to be switched on and off on the same side of the vehicle by the same activation device. They must flash synchronously.
Tell-tale ECE-R48 § 6.5.8	No requirements
Other regulations ECE-R48 § 6.5.3	Side direction indicators in category 5 may always be replaced with category 6.

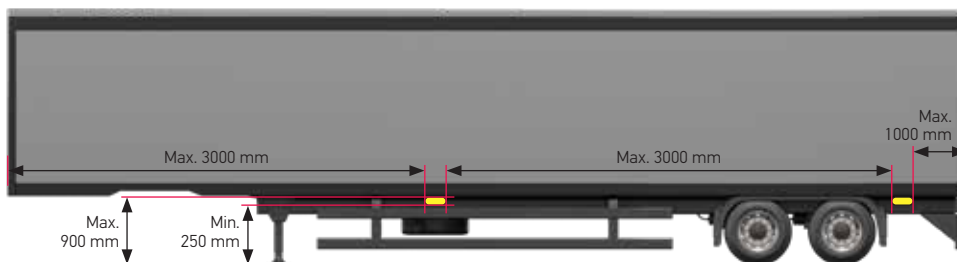

Reflectors (non-triangular)

ECE-R48 section 6.17 and ECE-R3 or ECE-R150

Presence ECE-R48 § 6.17.1	Prescribed for all trailers.
Number ECE-R48 § 6.17.2	See position in length.
Color ECE-R48 § 5.15	Amber
Form ECE-R48 § 6.17	Not triangular
Position in height ECE-R48 § 6.17.4.2	Min. 250 mm, max. 900 mm, max. 1,200 mm if integrated in another lamp (exception: 1,500 mm)*. * An exception is only possible if the vehicle geometry does not make standard installation possible.
Position in length ECE-R48 § 6.17.4.3	The reflex reflector installed at the foremost point must not be further than max. 3 m from the front of the vehicle. Max. 3 m between the individual reflex reflectors (exception: 4 m). Max. clearance from rear 1 m, min. 1 reflex reflector in the middle third.
Visibility ECE-R48 § 6.17.5	Horizontal ± 45°. Vertical ± 10°, but for a position in height of < 750 mm 5° downwards.
Other regulations ECE-R48 § 6.17.9	The illuminating surface of the reflex reflector may be integrated in any other position lamp.

Side lighting

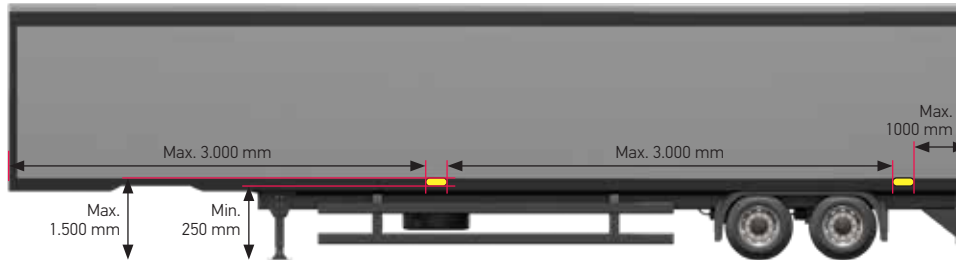

Side marker lamps

ECE-R48 section 6.18 and ECE-R91 or ECE-R148

Presence ECE-R48 § 6.18.1	Mandatory for all trailers > 6 m long. Optional for trailers < 6 m long. The SM1 type of side-marker lamp shall be used on all categories of vehicles.
Number ECE-R48 § 6.18.2	Minimum number per side. Such that the rules for longitudinal positioning are complied with.
Color ECE-R48 § 5.15	Front amber, rear amber (in combination with the combination rear lamp, red is also possible)
Position in height ECE-R48 § 6.18.4.2	Min. 250 mm, max. 1,500 mm (exception: 2,100 mm)*. * An exception is only possible if the vehicle geometry does not make standard installation possible.
Position in length ECE-R48 § 6.18.4.3	Foremost max. 3 m from the front, rearmost max. 1 m from rear, max. 3 m between the individual side marker lamps (exception: 4 m). Min. 1 m in the front and / or rear third. For vehicle lengths of ≤ 6 m and for chassis-cabs min. one within the first third and / or within the last third of the vehicle length.
Visibility ECE-R48 § 6.18.5	Horizontal ± 45°, with optional side marker lamps ± 30°. Vertical ± 10°, but for a position in height of < 750 mm 5° downwards.
Electrical connections ECE-R48 § 6.18.7	For vehicles of category O3 and O4 the side marker lamps may flash with the direction indicators, but not if there are side direction indicators installed.
Tell-tale ECE-R48 § 6.18.8	Approved. If there is a tell-tale, its function must be met by the mandatory tell-tale for the position lamps and tail lamps.
Other regulations ECE-R48 § 6.18.9	The rear side marker lamps must be amber if they flash together with the rear direction indicator. The illuminating surface of the reflector may be integrated into the side indicator lamp. The max. position in height of the reflex reflector needs to be observed here.

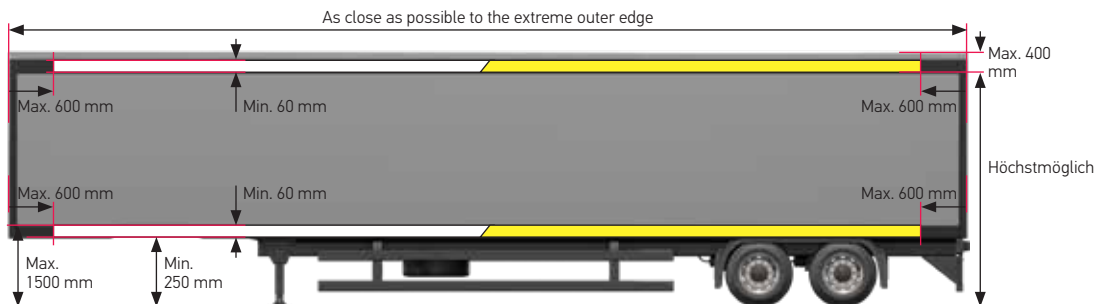

Contour markings

ECE-R48 section 6.21 and ECE-R104 or ECE-R150

Presence ECE-R48 § 6.21.1	Partial contour marking mandatory on O3 and O4 vehicles with a length of > 6,000 mm (exception: incomplete vehicles). However, if it is not possible to install the mandatory contour marking, line markings may be installed. Optional on vehicles in all other classes except O1 vehicles. A full contour marking may be used in place of a mandatory partial contour marking. Partial or full contour marking is permissible in place of mandatory line markings. Optional, to the front, line marking on vehicles O2, O3 and O4. Partial or full contour marking may not be applied to the front.
Attachment method ECE-R48 § 6.21.3	Horizontal and vertical if compatible with the shape, structure and design of the vehicle.
Color ECE-R48 § 5.15	White or yellow
Position in width ECE-R48 § 6.21.4.1	The conspicuity marking shall be as close as practicable to the edge of the vehicle. The cumulative horizontal length of the conspicuity marking elements, as mounted on the vehicle, shall equate to at least 70 % of the overall width of the vehicle, excluding any horizontal overlap of individual elements.
Position in height ECE-R48 § 6.21.4.3	Lower marking: as low as possible, but min. 250 mm above the ground, max. 1,500 mm above the ground (exception: to 2,500 mm). Upper marking: as high as possible, max. 400 mm from the upper edge of the vehicle.
Position in length ECE-R48 § 6.21.4.2	The conspicuity marking shall be as close as practicable to the ends of the vehicle and reach to within 600 mm of each end of the vehicle. For trailers, each end of the vehicle (excluding the drawbar). The cumulative horizontal length of the conspicuity marking elements, as mounted on the vehicle, shall equate to at least 70 % of the overall length of the vehicle, (excluding the drawbar), excluding any horizontal overlap of individual elements.
Visibility ECE-R48 § 6.21.5	Min. 70 % of the marking must be visible to an onlooker.
Position on side ECE-R48 § 6.21.6.1	As close as practicable to being parallel to the median longitudinal plane of the vehicle.
Other regulations ECE-R48 § 6.21.7	<ol style="list-style-type: none"> 1. Conspicuity markings are deemed continuous if the clearances between parts arranged next to each other is as small as possible and no more than 50% of the shortest length of one of these parts. (If this is not possible, a value > 50 % but < 1 m is allowed.) 2. In the case of a partial contour marking, each upper corner must be clearly marked by two lines at angles of 90°; each line must be min. 250 mm long 3. The locations of the vehicle where the conspicuity markings are to be installed must be big enough to bear markings that are min. 60 mm wide.

Rear lighting



Direction indicators

ECE-R48 section 6.5 and ECE-R6 or ECE-R148

Presence ECE-R48 § 6.5.1	Prescribed for all trailers. Category 2a or 2b.
Number ECE-R48 § 6.5.3	2 lamps, additional 2 optional on O2, O3 and O4 vehicles.
Color ECE-R48 § 5.15	Amber
Position in width ECE-R48 § 6.5.4.1	Max. 400 mm from the extreme outer edge of the vehicle. This does not apply to the additional indicators. Min. 600 mm between the two indicators, but min. 400 mm for vehicle widths < 1,300 mm.
Position in height ECE-R48 § 6.5.4.2	Min. 350 mm, max. 1,500 mm (exception: 2,100 mm, only if the vehicle geometry does not allow for an installation of less than 1,500 mm and if 2 additional indicators are not installed). Position in height of the additional indicators: min. 600 mm above the mandatory indicators.
Visibility ECE-R48 § 6.5.5	Horizontal 45° inwards to 80° outwards. Vertical ± 15°, but for a position in height of < 750 mm also 5° downwards. Optionally with a position in height of 2,100 mm also 5° upwards.
Electrical connections ECE-R48 § 6.5.7	It must switch on independently of the other lamps. They need to be switched on and off on the same side of the vehicle by the same activation device. They must flash synchronously.
Tell-tale ECE-R48 § 6.5.8	Prescribed. The tell-tale is mandatory for the front and rear direction indicators. Vehicles which are equipped to tow a trailer must feature a tell-tale for the direction indicator of the trailer. This is unless every malfunction in the direction indicator of the convoy can be signaled via the tell-tale of the towing vehicle. The tell-tale is not necessary for the two additional direction indicators on trailers.



Stop lights

ECE-R48 section 6.7 and ECE-R7 or ECE-R148

Presence ECE-R48 § 6.7.1	Prescribed for all trailers. Category S1 or S2.
Number ECE-R48 § 6.7.2	Two Except if stop lamps in category S3 or S4 are installed, two additional stop lamps in category S1 or S2 can be installed to vehicle classes O2, O3 and O4.
Color ECE-R48 § 5.15	Red
Position in width ECE-R48 § 6.7.4.1	For all trailers min. 600 mm between both stop lamps, but min. 400 mm for vehicle widths < 1,300 mm.
Position in height ECE-R48 § 6.7.4.2	Min. 350 mm, max. 1,500 mm (exception: 2,100 mm, only if the vehicle geometry does not allow for an installation of less than 1,500 mm and 2 additional stop lamps are not installed). Position in height of the additional stop lamps: min. 600 mm above the mandatory stop lamps.
Visibility ECE-R48 § 6.7.5	Horizontal ± 45°. Vertical ± 15°, but for a position in height of < 750 mm also 5° downwards. Optionally with a position in height of 2,100 mm also 5° upwards.
Electrical connections ECE-R48 § 6.7.7	Must shine when the brake is pressed.
Tell-tale ECE-R48 § 6.7.8	Optional, however, a tell-tale indicating failure is mandatory if required by the component regulation. If there is one, only as an operating tell-tale in the shape of a non-flashing warning lamp that lights up in the event of a fault.
Other regulations ECE-R48 § 6.11.9	In all cases, the distance between the rear fog-lamp and each stop-lamp shall be greater than 100 mm.

Rear lighting



Center high mounted stop lamp (CHMSL)

ECE-R48 section 6.7 and ECE-R7 or ECE-R148

Presence ECE-R48 § 6.7.1 ECE-R7 § 6.1	(1) Optional for all trailers, category S3 or S4, except if additional stop lamps of the category S1 or S2 are installed. (2) Category S3 or S4: <ul style="list-style-type: none"> ■ Category S3 (fixed): luminous intensity min. 25 cd, single lamp max. 110 cd, type "D" lamp max. 55 cd ■ Category S4 (variable): luminous intensity min. 25 cd, single lamp max. 160 cd, type "D" lamp max. 80 cd
Number ECE-R48 § 6.7.2	One If the median longitudinal plane of the vehicle is not located on a fixed body panel but separates e.g. doors and there is no space for an S3 or S4 stop lamp, two S3 or S4 stop lamps of the type "D" stop lamp or an S3 or S4 stop lamp can be installed to the left or right of the median longitudinal plane of the vehicle.
Color ECE-R48 § 5.15	Red
Position in width ECE-R48 § 6.7.4.1	The reference point must lie in the median longitudinal plane of the trailer. If two S3 or S4 stop lamps are installed, each one needs to be installed as close as possible to the median longitudinal plane. If only one S3 or S4 stop lamp is installed next to the median longitudinal plane, the clearance may not be greater than 150 mm.
Position in height ECE-R48 § 6.7.4.2	Max. 150 mm below the rear window or min. 850 mm above the ground. Above the S1 and S2 stop lamps.
Visibility ECE-R48 § 6.7.5	Horizontal $\pm 10^\circ$. Vertical 10° over and 5° below the horizontal.
Electrical connections ECE-R48 § 6.7.7	Must light up when the braking system sends a corresponding signal.
Tell-tale ECE-R48 § 6.7.8	Optional, however, a tell-tale indicating failure is mandatory if required by the component regulation. If there is one, only as an operating tell-tale in the shape of a non-flashing warning lamp that lights up in the event of a fault.



Reversing lamp(s)

ECE-R48 section 6.4 and ECE-R23 or ECE-R148

Presence ECE-R48 § 6.4.1	Mandatory for all trailers of the vehicle classes O2, O3 and O4. Optional for trailers of the vehicle class O1.
Number ECE-R48 § 6.4.2	One device mandatory and a second one optional for trailers with a length of ≤ 6 m. Two devices mandatory and two devices optional* on all trailers with lengths of > 6 m.
Color ECE-R48 § 5.15	White
Position in width ECE-R48 § 6.4.4.1	No requirements
Position in height ECE-R48 § 6.4.4.2	Min. 250 mm, max. 1,200 mm.
Position in length ECE-R48 § 6.4.4.3	At the end of the vehicle according to § 6.4.5.2. The two optional devices may be installed also on the side according to § 6.4.6.2. In both cases: The geometric visibility is considered to be ensured if the reference axis of the respective device is directed outwards with an angle β not exceeding 15° relative to the median longitudinal plane of the vehicle. The vertical aim of the two optional devices may be directed downwards.
Visibility ECE-R48 § 6.4.5	One lamp: horizontal $\pm 45^\circ$. Two lamps: Horizontal 30° inwards to 45° outwards. Vertical 15° upwards, to 5° downwards.
Electrical connections ECE-R48 § 6.4.7	Only activated when the reverse gear is engaged and the vehicle is in running order. The special conditions in section § 6.4.7.2 apply to the optional reversing lamps.
Tell-tale ECE-R48 § 6.4.8	Optional

* Installation of the two optional reversing lamps also allowed on the vehicle side.

Rear lighting



Fog lamp(s)

ECE-R48 section 6.11 and ECE-R38 or ECE-R148

Presence ECE-R48 § 6.11.1	Prescribed for all trailers. Category F, F1 or F2.
Number ECE-R48 § 6.11.2	One or two
Color ECE-R48 § 5.15	Red
Position in width ECE-R48 § 6.11.4.1	One rear fog lamp installed: left of center = right-hand traffic, right of center = left-hand traffic. Presence in the middle is allowed. Two fog lamps installed: left and right sides of the vehicle.
Position in height ECE-R48 § 6.11.4.2	Min. 250 mm, max. 1,000 mm or if mounted with another function max. 1,200 mm.
General position ECE-R48 § 6.11.9 ECE-R48 § 6.11.4.1	The distance to the stop lamp must be > 100 mm. If only 1 rear fog lamp: left of center in case of right-hand traffic, right of center in case of left-hand traffic. Presence on the centerline is allowed.
Visibility ECE-R48 § 6.11.5	Horizontal $\pm 25^\circ$, vertical $\pm 5^\circ$
Electrical connections ECE-R48 § 6.11.7	Cannot be switched on unless the low beam, high beam or fog lamps are switched on.
Tell-tale ECE-R48 § 6.11.8	Circuit-closed tell-tale mandatory. An independent, non-flashing warning light.
Other regulations ECE-R48 § 6.11.7.5	The rear fog lamp(s) of a drawing motor vehicle may be automatically switched OFF while a trailer is connected and the rear fog lamp(s) of the trailer is (are) switched ON.



Registration plate lamp(s)

ECE-R48 section 6.8 and ECE-R4 or ECE-R148

Presence ECE-R48 § 6.8.1	Mandatory
Number ECE-R48 § 6.8.2	One; additional lamps permitted to meet requirements.
Color ECE-R48 § 5.15	White
Attachment method ECE-R48 § 6.8.3	In a way that the registration plate is illuminated.
Visibility ECE R4 and R148	The devices for the illumination of rear-registration plates of categories: <ul style="list-style-type: none"> ■ 1a (tall plate (340 x 240 mm)) ■ 1b (wide plate (520 x 120 mm)) ■ 1c (plate for agricultural or forestry tractors (255 x 165 mm)) ■ 2a (small plate (330 x 165 mm)) and ■ 2b (wide plate (440 x 220 mm)) shall be so constructed that the whole surface of the plate will be visible within the angles given in Part D of Annex 2. The manufacturer of the illuminating device shall specify one or more or a field of positions in which the device is to be fitted in relation to the space for the registration plate; when the lamp is placed in the position(s) specified by the manufacturer the angle of incidence of the light on the surface of the plate does not exceed 82° at any point on the surface to be illuminated, this angle being measured from the extremity of the device's illuminating area which is furthest from the surface of the plate. If there is more than one illuminating device, the foregoing requirement shall apply only to that part of the plate intended to be illuminated by the device concerned.
Electrical connections ECE-R48 § 6.8.7	Must be designed so that the sidelight, licence plate light, tail light and side marker lights can only be switched on and off simultaneously.
Tell-tale ECE-R48 § 6.8.8	Optional. If there is a tell-tale, its function must be satisfied by the mandatory tell-tale for the position lamps and tail lamps.
Other regulations ECE-R48 § 6.8.9	When the rear registration plate lamp is combined with the rear position lamp, reciprocally incorporated in the stop lamp or in the rear fog lamp, the photometric characteristics of the rear registration plate lamp may be modified during the entire time of the stop lamp or the rear fog lamp is switched ON.

Rear lighting



Reflectors (triangular)

ECE-R48 section 6.14 and ECE-R3 or ECE-R150

Presence ECE-R48 § 6.15.1	Prescribed for all trailers. Prohibited on motor vehicles.
Number ECE-R48 § 6.15.2	Two; additional devices optional
Color ECE-R48 § 5.15	Red
Form ECE-R48 § 6.15	Triangular
Attachment method ECE-R48 § 6.15.3	The tip of the triangle must point upwards.
Position in width ECE-R48 § 6.15.4.1	Max. 400 mm from the extreme outer edge of the vehicle, min. 600 mm between the two reflex reflectors, but min. 400 mm for vehicle widths of < 1,300 mm.
Position in height ECE-R48 § 6.15.4.2	Min. 250 mm, max. 900 mm, max. 1,200 mm if integrated in another lamp (exception: 1,500 mm if impossible to keep within 1,200 mm)*.
Visibility ECE-R48 § 6.15.5	Horizontal $\pm 30^\circ$. Vertical $\pm 15^\circ$, but for a position in height of < 750 mm only up to 5° downwards.
Other regulations ECE-R48 § 6.15.7	The illuminating surface of the reflex reflector may be integrated in any other rear lamp.

* An exception is only possible if the vehicle geometry does not make standard installation possible.

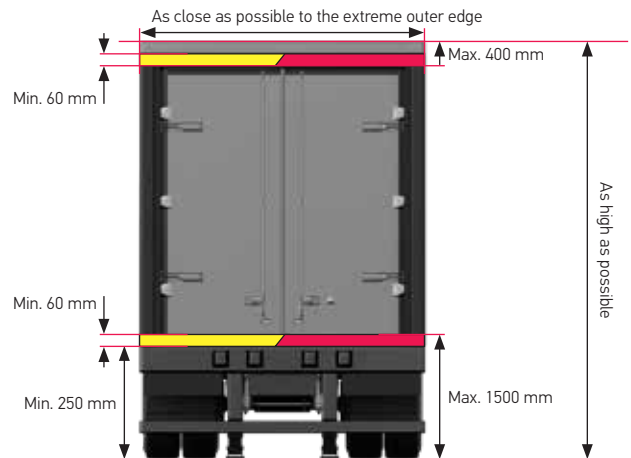

Contour markings

ECE-R48 section 6.21 and ECE-R104 or ECE-R150

Presence ECE-R48 § 6.21.1	Prohibited on O1. Full contour markings mandatory in the following classes with a width of > 2,100 mm: O3 and O4 vehicles (exception: incomplete vehicles). However, if it is not possible to install the mandatory contour markings due to the shape, structure, type or operating conditions, line markings may be installed. Optional, to the rear and to the side, on vehicles in all other classes except O1 vehicles. A full contour marking may be used in place of a mandatory partial contour marking. Partial or full contour marking is permissible in place of mandatory line markings. Optional, to the front, Line marking on vehicles O2, O3 and O4. Partial or full contour marking may not be applied to the front.
Attachment method ECE-R48 § 6.21.3	Horizontal and vertical if compatible with the shape, structure and design of the vehicle.
Color ECE-R48 § 5.15	Red or yellow to the rear (some countries allow white)
Position in width ECE-R48 § 6.21.4.1	The conspicuity marking shall be as close as practicable to the edge of the vehicle. The cumulative horizontal length of the conspicuity marking elements, as mounted on the vehicle, shall equate to at least 70 % of the overall width of the vehicle, excluding any horizontal overlap of individual elements.
Position in height ECE-R48 § 6.21.4.3	Lower marking: as low as possible, but min. 250 mm above the ground, max. 1,500 mm above the ground (exception: to 2,500 mm). Upper marking: as high as possible, max. 400 mm from the upper edge of the vehicle.
Position in length ECE-R48 § 6.21.4.2	The conspicuity marking shall be as close as practicable to the ends of the vehicle and reach to within 600 mm of each end of the vehicle. For trailers, each end of the vehicle (excluding the drawbar). The cumulative horizontal length of the conspicuity marking elements, as mounted on the vehicle, shall equate to at least 70 % of the overall length of the vehicle, (excluding the drawbar), excluding any horizontal overlap of individual elements.
Visibility ECE-R48 § 6.21.5	Min. 70 % of the marking must be visible to an onlooker.
Position to the rear and to the front ECE-R48 § 6.21.6.2	As close as practicable to being parallel to the transverse plane of the vehicle.
Other regulations ECE-R48 § 6.21.7	<ol style="list-style-type: none"> 1. Conspicuity markings are deemed continuous if the clearances between parts arranged next to each other is as small as possible and no more than 50% of the shortest length of one of these parts. (if this is not possible, a value > 50 % but < 1 m is allowed.) 2. The clearance between the conspicuity markings installed at the rear of the vehicle and every mandatory stop lamp should be greater than 200 mm. 3. If rear registration plates of regulation ECE-R70 or to ECE-R150, are installed, these can be considered as part of the rear conspicuity marking at the manufacturer's discretion when calculating the conspicuity marking and its clearance to the side of the vehicle. 4. The locations of the vehicle where the conspicuity markings are to be installed must be big enough to bear markings that are min. 60 mm wide.



HELLA GmbH & Co. KGaA

Trailerwerk Nellingen

Amstetter Straße 32

89191 Nellingen

Tel.: +49 7337 9615-0 Zentrale

Tel.: +49 7337 9615-50 Vertrieb

Fax: +49 7337 9615-33 Vertrieb

Internet: www.hella.com/trailer

© HELLA KGaA GmbH & Co. KGaA, Lippstadt
J01876/06.22

Subject to technical and price modifications.

www.hella.com/trailer